

Chapter 7

Advanced Composite Materials

Description of Composite Structures

Introduction

Composite materials are becoming more important in the construction of aerospace structures. Aircraft parts made from composite materials, such as fairings, spoilers, and flight controls, were developed during the 1960s for their weight savings over aluminum parts. New generation large aircraft are designed with all composite fuselage and wing structures, and the repair of these advanced composite materials requires an in-depth knowledge of composite structures, materials, and tooling. The primary advantages of composite materials are their high strength, relatively low weight, and corrosion resistance.

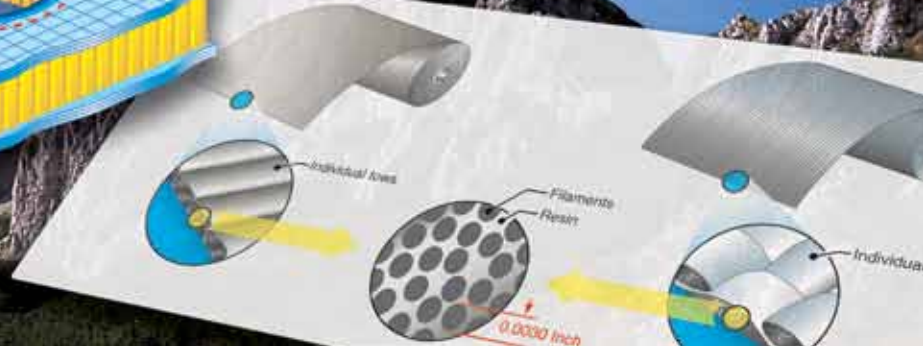
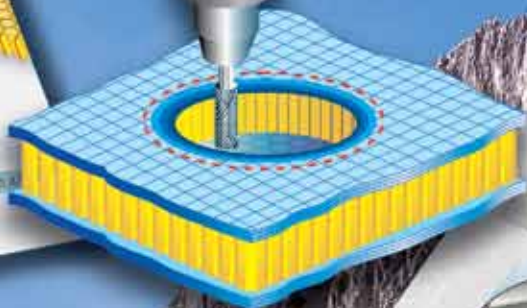
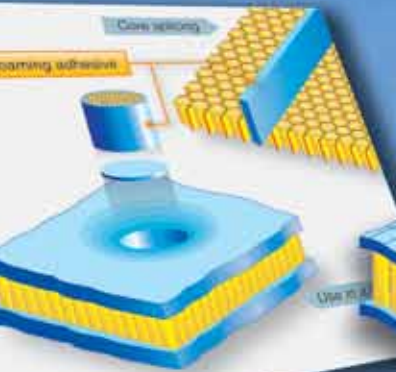
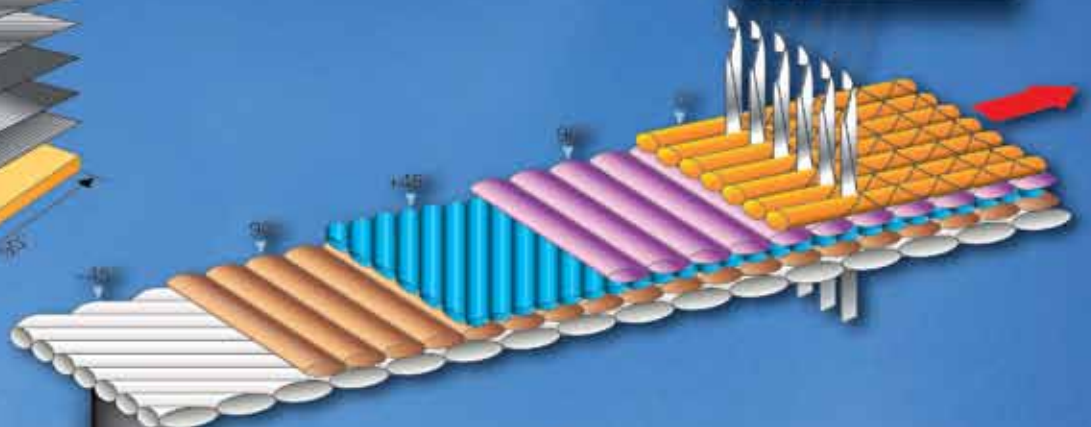
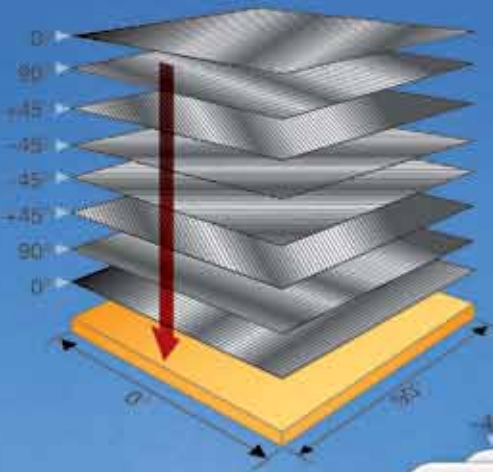

Laminated Structures

Composite materials consist of a combination of materials that are mixed together to achieve specific structural properties. The individual materials do not dissolve or merge completely in the composite, but they act together as one. Normally, the components can be physically identified as they interface with one another. The properties of the composite material are superior to the properties of the individual materials from which it is constructed.

An advanced composite material is made of a fibrous material embedded in a resin matrix, generally laminated with fibers oriented in alternating directions to give the material strength and stiffness. Fibrous materials are not new; wood is the most common fibrous structural material known to man.

Applications of composites on aircraft include:

- Fairings
- Flight control surfaces
- Landing gear doors
- Leading and trailing edge panels on the wing and stabilizer
- Interior components
- Floor beams and floor boards
- Vertical and horizontal stabilizer primary structure on large aircraft
- Primary wing and fuselage structure on new generation large aircraft
- Turbine engine fan blades
- Propellers

Major Components of a Laminate

An isotropic material has uniform properties in all directions. The measured properties of an isotropic material are independent of the axis of testing. Metals such as aluminum and titanium are examples of isotropic materials.

A fiber is the primary load carrying element of the composite material. The composite material is only strong and stiff in the direction of the fibers. Unidirectional composites have predominant mechanical properties in one direction and are said to be anisotropic, having mechanical and/or physical properties that vary with direction relative to natural reference axes inherent in the material. Components made from fiber-reinforced composites can be designed so that the fiber orientation produces optimum mechanical properties, but they can only approach the true isotropic nature of metals, such as aluminum and titanium.

A matrix supports the fibers and bonds them together in the composite material. The matrix transfers any applied loads to the fibers, keeps the fibers in their position and chosen orientation, gives the composite environmental resistance, and determines the maximum service temperature of a composite.

Strength Characteristics

Structural properties, such as stiffness, dimensional stability, and strength of a composite laminate, depend on the stacking sequence of the plies. The stacking sequence describes the distribution of ply orientations through the laminate thickness. As the number of plies with chosen orientations increases, more stacking sequences are possible. For example, a symmetric eight-ply laminate with four different ply orientations has 24 different stacking sequences.

Fiber Orientation

The strength and stiffness of a composite buildup depends on the orientation sequence of the plies. The practical range of strength and stiffness of carbon fiber extends from values as low as those provided by fiberglass to as high as those provided by titanium. This range of values is determined by the orientation of the plies to the applied load. Proper selection of ply orientation in advanced composite materials is necessary to provide a structurally efficient design. The part might require 0° plies to react to axial loads, ±45° plies to react to shear loads, and 90° plies to react to side loads. Because the strength design requirements are a function of the applied load direction, ply orientation and ply sequence have to be correct. It is critical during a repair to replace each damaged ply with a ply of the same material and ply orientation.

The fibers in a unidirectional material run in one direction and the strength and stiffness is only in the direction of the fiber. Pre-impregnated (prepreg) tape is an example of a unidirectional ply orientation.

The fibers in a bidirectional material run in two directions, typically 90° apart. A plain weave fabric is an example of a bidirectional ply orientation. These ply orientations have strength in both directions but not necessarily the same strength. [Figure 7-1]

The plies of a quasi-isotropic layup are stacked in a 0°, -45°, 45°, and 90° sequence or in a 0°, -60°, and 60° sequence. [Figure 7-2] These types of ply orientation simulate the properties of an isotropic material. Many aerospace composite structures are made of quasi-isotropic materials.

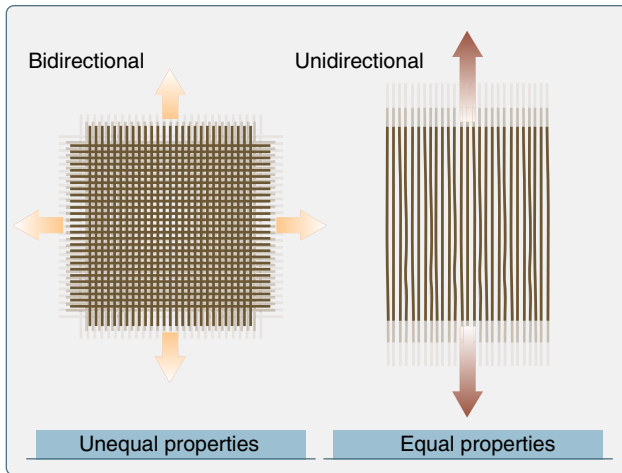

Figure 7-1. Bidirectional and unidirectional material properties.

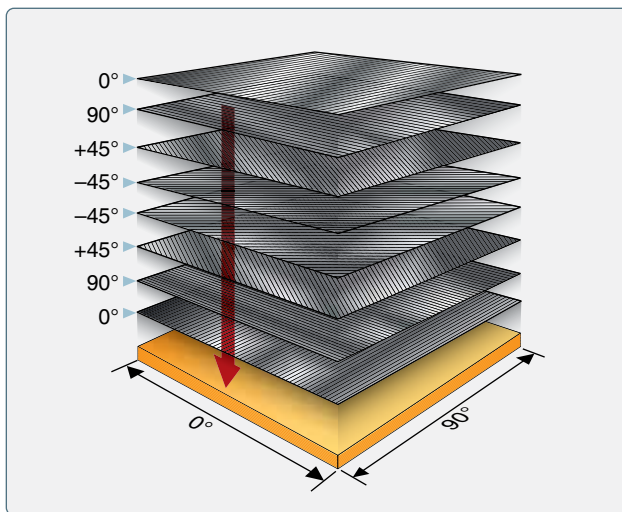

Figure 7-2. Quasi-isotropic material lay-up.

Warp Clock

Warp indicates the longitudinal fibers of a fabric. The warp is the high strength direction due to the straightness of the fibers. A warp clock is used to describe direction of fibers on a diagram, spec sheet, or manufacturer's sheets. If the warp clock is not available on the fabric, the orientation is defaulted to zero as the fabric comes off the roll. Therefore, 90° to zero is the width of the fabric across. [Figure 7-3]

Fiber Forms

All product forms generally begin with spooled unidirectional raw fibers packaged as continuous strands. An individual fiber is called a filament. The word strand is also used to identify an individual glass fiber. Bundles of filaments are identified as tows, yarns, or rovings. Fiberglass yarns are twisted, while Kevlar® yarns are not. Tows and rovings do not have any twist. Most fibers are available as dry fiber that needs to be impregnated (impreg) with a resin before use or prepreg materials where the resin is already applied to the fiber.

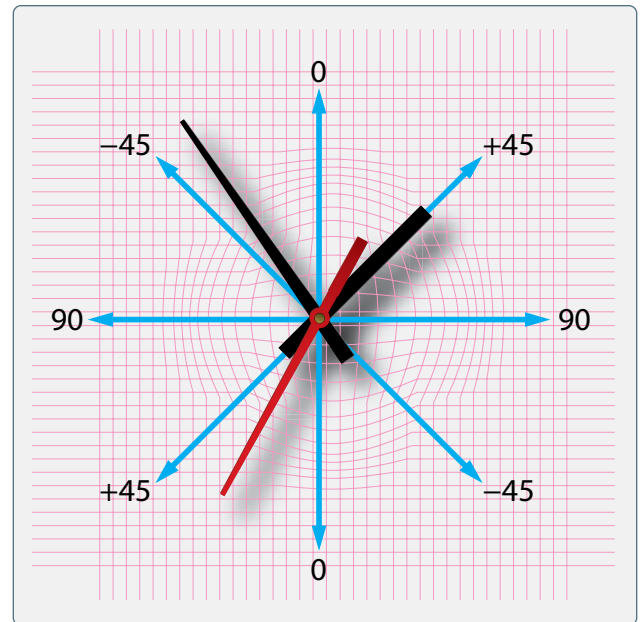

Figure 7-3. A warp clock.

Roving

A roving is a single grouping of filament or fiber ends, such as 20-end or 60-end glass rovings. All filaments are in the same direction and they are not twisted. Carbon rovings are usually identified as 3K, 6K, or 12K rovings, K meaning 1,000 filaments. Most applications for roving products utilize mandrels for filament winding and then resin cure to final configuration.

Unidirectional (Tape)

Unidirectional prepreg tapes have been the standard within the aerospace industry for many years, and the fiber is typically impregnated with thermosetting resins. The most common method of manufacture is to draw collimated raw (dry) strands into the impregnation machine where hot melted resins are combined with the strands using heat and pressure. Tape products have high strength in the fiber direction and virtually no strength across the fibers. The fibers are held in place by the resin. Tapes have a higher strength than woven fabrics. [Figure 7-4]

Bidirectional (Fabric)

Most fabric constructions offer more flexibility for layup of complex shapes than straight unidirectional tapes offer. Fabrics offer the option for resin impregnation either by solution or the hot melt process. Generally, fabrics used for structural applications use like fibers or strands of the same weight or yield in both the warp (longitudinal) and fill (transverse) directions. For aerospace structures, tightly woven fabrics are usually the choice to save weight, minimizing resin void size, and maintaining fiber orientation during the fabrication process.

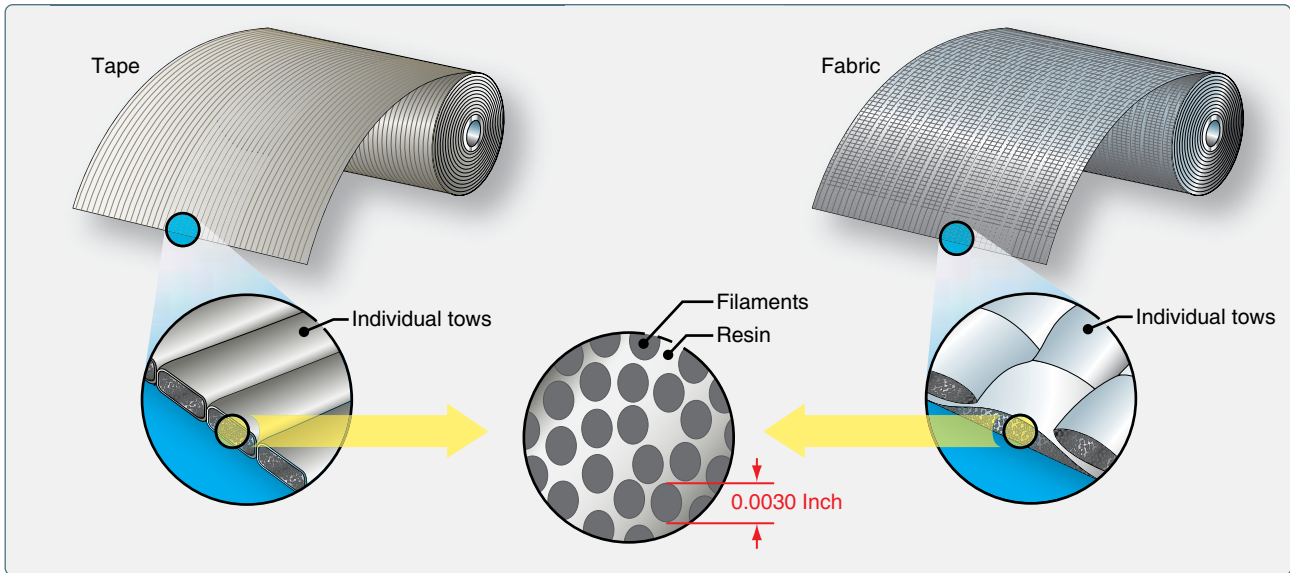

Figure 7-4. Tape and fabric products.

Woven structural fabrics are usually constructed with reinforcement tows, strands, or yarns interlocking upon themselves with over/under placement during the weaving process. The more common fabric styles are plain or satin weaves. The plain weave construction results from each fiber alternating over and then under each intersecting strand (tow, bundle, or yarn). With the common satin weaves, such as 5 harness or 8 harness, the fiber bundles traverse both in warp and fill directions changing over/under position less frequently.

These satin weaves have less crimp and are easier to distort than a plain weave. With plain weave fabrics and most 5 or 8 harness woven fabrics, the fiber strand count is equal in both warp and fill directions. Example: 3K plain weave often has an additional designation, such as 12 x 12, meaning there are twelve tows per inch in each direction. This count designation can be varied to increase or decrease fabric weight or to accommodate different fibers of varying weight. [Figure 7-5]

Nonwoven (Knitted or Stitched)

Knitted or stitched fabrics can offer many of the mechanical advantages of unidirectional tapes. Fiber placement can be straight or unidirectional without the over/under turns of woven fabrics. The fibers are held in place by stitching with fine yarns or threads after preselected orientations of one or more layers of dry plies. These types of fabrics offer a wide range of multi-ply orientations. Although there may be some added weight penalties or loss of some ultimate reinforcement fiber properties, some gain of interlaminar shear and toughness properties may be realized. Some common stitching yarns are polyester, aramid, or thermoplastics. [Figure 7-6]

Types of Fiber

Fiberglass

Fiberglass is often used for secondary structure on aircraft, such as fairings, radomes, and wing tips. Fiberglass is also used for helicopter rotor blades. There are several types of fiberglass used in the aviation industry. Electrical glass, or E-glass, is identified as such for electrical applications. It has high resistance to current flow. E-glass is made from borosilicate glass. S-glass and S2-glass identify structural fiberglass that have a higher strength than E-glass. S-glass is produced from magnesia-alumina-silicate. Advantages of fiberglass are lower cost than other composite materials, chemical or galvanic corrosion resistance, and electrical properties (fiberglass does not conduct electricity). Fiberglass has a white color and is available as a dry fiber fabric or prepreg material.

Kevlar®

Kevlar® is DuPont's name for aramid fibers. Aramid fibers are light weight, strong, and tough. Two types of Aramid fiber are used in the aviation industry. Kevlar® 49 has a high stiffness and Kevlar® 29 has a low stiffness. An advantage of aramid fibers is their high resistance to impact damage, so they are often used in areas prone to impact damage. The main disadvantage of aramid fibers is their general weakness in compression and hygroscopy. Service reports have indicated that some parts made from Kevlar® absorb up to 8 percent of their weight in water. Therefore, parts made from aramid fibers need to be protected from the environment. Another disadvantage is that Kevlar® is difficult to drill and cut. The fibers fuzz easily and special scissors are needed to cut the

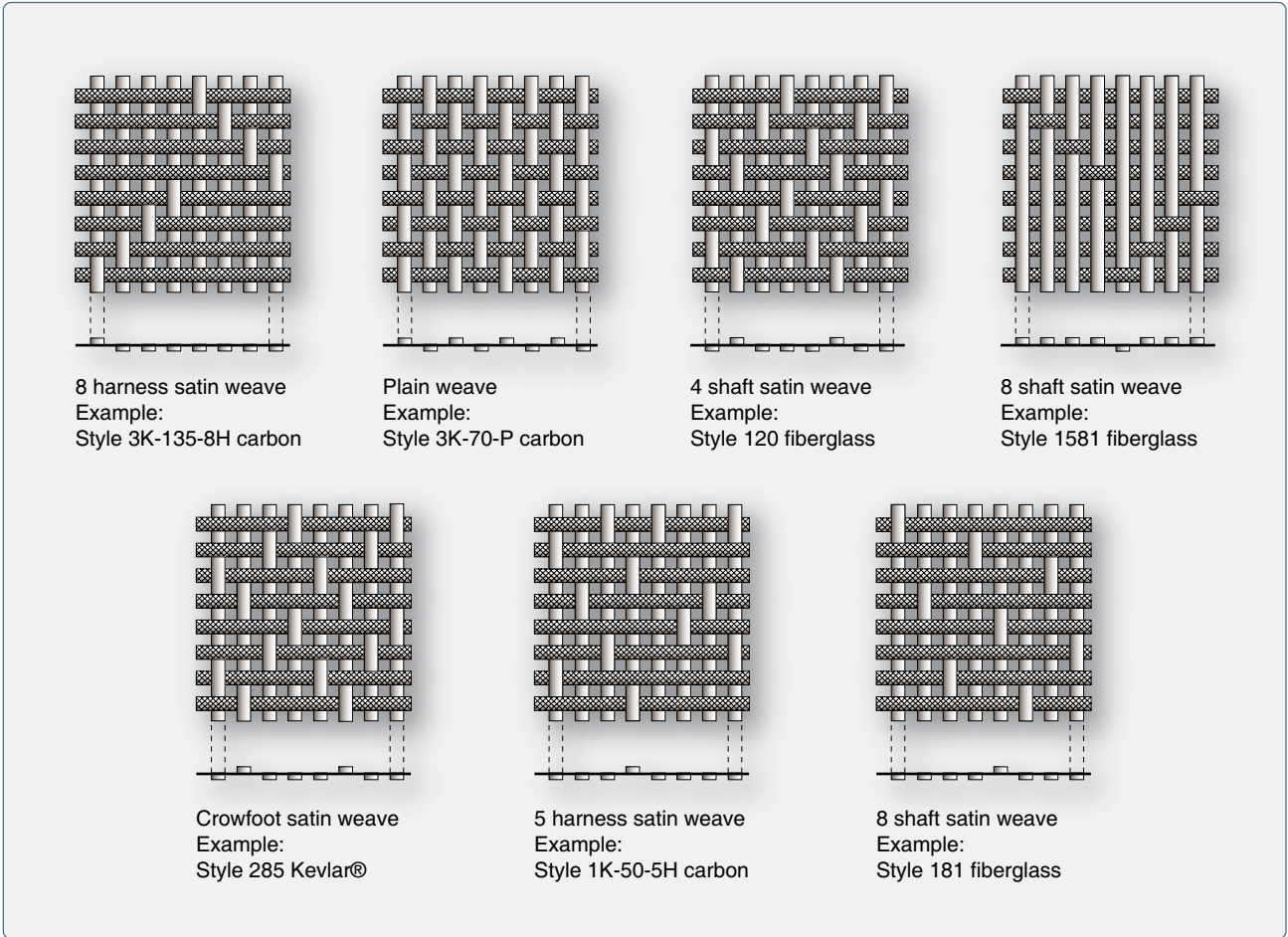

Figure 7-5. Typical fabric weave styles.

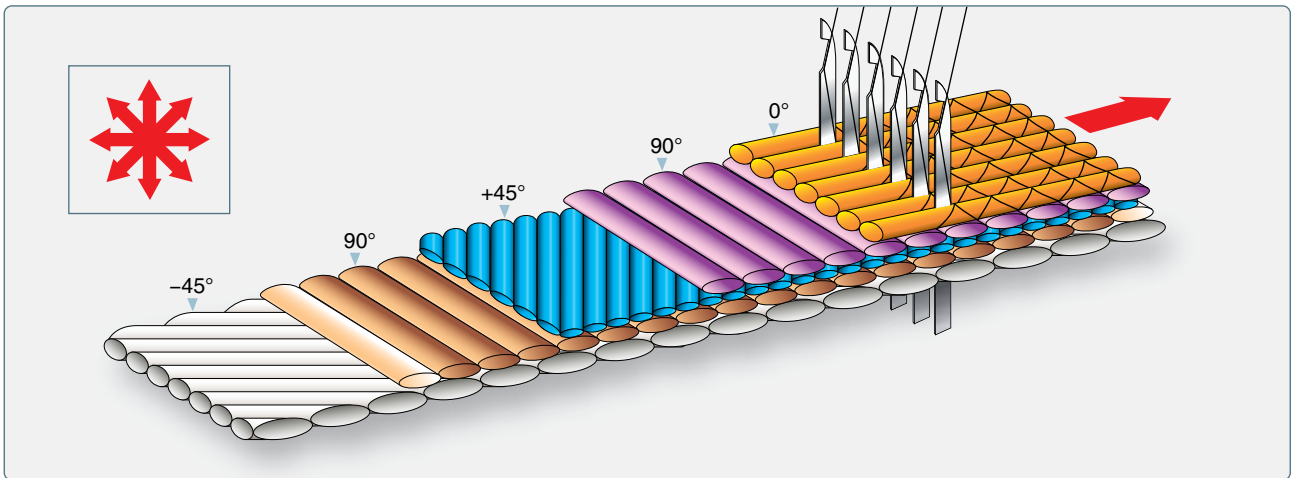

Figure 7-6. Nonwoven material (stitched).

material. Kevlar® is often used for military ballistic and body armor applications. It has a natural yellow color and is available as dry fabric and prepreg material. Bundles of

aramid fibers are not sized by the number of fibers like carbon or fiberglass but by the weight.

Carbon/Graphite

One of the first distinctions to be made among fibers is the difference between carbon and graphite fibers, although the terms are frequently used interchangeably. Carbon and graphite fibers are based on graphene (hexagonal) layer networks present in carbon. If the graphene layers, or planes, are stacked with three dimensional order, the material is defined as graphite. Usually extended time and temperature processing is required to form this order, making graphite fibers more expensive. Bonding between planes is weak. Disorder frequently occurs such that only two-dimensional ordering within the layers is present. This material is defined as carbon.

Carbon fibers are very stiff and strong, 3 to 10 times stiffer than glass fibers. Carbon fiber is used for structural aircraft applications, such as floor beams, stabilizers, flight controls, and primary fuselage and wing structure. Advantages include its high strength and corrosion resistance. Disadvantages include lower conductivity than aluminum; therefore, a lightning protection mesh or coating is necessary for aircraft parts that are prone to lightning strikes. Another disadvantage of carbon fiber is its high cost. Carbon fiber is gray or black in color and is available as dry fabric and prepreg material. Carbon fibers have a high potential for causing galvanic corrosion when used with metallic fasteners and structures. [Figure 7-7]



Figure 7-7. Fiberglass (left), Kevlar® (middle), and carbon fiber material (right).

Boron

Boron fibers are very stiff and have a high tensile and compressive strength. The fibers have a relatively large diameter and do not flex well; therefore, they are available only as a prepreg tape product. An epoxy matrix is often used with the boron fiber. Boron fibers are used to repair cracked aluminum aircraft skins, because the thermal expansion of boron is close to aluminum and there is no galvanic corrosion

potential. The boron fiber is difficult to use if the parent material surface has a contoured shape. The boron fibers are very expensive and can be hazardous for personnel. Boron fibers are used primarily in military aviation applications.

Ceramic Fibers

Ceramic fibers are used for high-temperature applications, such as turbine blades in a gas turbine engine. The ceramic fibers can be used to temperatures up to 2,200 °F.

Lightning Protection Fibers

An aluminum airplane is quite conductive and is able to dissipate the high currents resulting from a lightning strike. Carbon fibers are 1,000 times more resistive than aluminum to current flow, and epoxy resin is 1,000,000 times more resistive (i.e., perpendicular to the skin). The surface of an external composite component often consists of a ply or layer of conductive material for lightning strike protection because composite materials are less conductive than aluminum. Many different types of conductive materials are used ranging from nickel-coated graphite cloth to metal meshes to aluminized fiberglass to conductive paints. The materials are available for wet layup and as prepreg.

In addition to a normal structural repair, the technician must also recreate the electrical conductivity designed into the part. These types of repair generally require a conductivity test to be performed with an ohmmeter to verify minimum electrical resistance across the structure. When repairing these types of structures, it is extremely important to use only the approved materials from authorized vendors, including such items as potting compounds, sealants, adhesives, and so forth. [Figures 7-8 and 7-9]



Figure 7-8. Copper mesh lightning protection material.



Figure 7-9. Aluminum mesh lightning protection material.

Matrix Materials

Thermosetting Resins

Resin is a generic term used to designate the polymer. The resin, its chemical composition, and physical properties fundamentally affect the processing, fabrication, and ultimate properties of a composite material. Thermosetting resins are the most diverse and widely used of all man-made materials. They are easily poured or formed into any shape, are compatible with most other materials, and cure readily (by heat or catalyst) into an insoluble solid. Thermosetting resins are also excellent adhesives and bonding agents.

Polyester Resins

Polyester resins are relatively inexpensive, fast processing resins used generally for low cost applications. Low smoke producing polyester resins are used for interior parts of the aircraft. Fiber-reinforced polyesters can be processed by many methods. Common processing methods include matched metal molding, wet layup, press (vacuum bag) molding, injection molding, filament winding, pultrusion, and autoclaving.

Vinyl Ester Resin

The appearance, handling properties, and curing characteristics of vinyl ester resins are the same as those of conventional polyester resins. However, the corrosion resistance and mechanical properties of vinyl ester composites are much improved over standard polyester resin composites.

Phenolic Resin

Phenol-formaldehyde resins were first produced commercially in the early 1900s for use in the commercial market. Urea-formaldehyde and melamine-formaldehyde appeared in the 1920–1930s as a less expensive alternative for lower

temperature use. Phenolic resins are used for interior components because of their low smoke and flammability characteristics.

Epoxy

Epoxyes are polymerizable thermosetting resins and are available in a variety of viscosities from liquid to solid. There are many different types of epoxy, and the technician should use the maintenance manual to select the correct type for a specific repair. Epoxyes are used widely in resins for prepreg materials and structural adhesives. The advantages of epoxyes are high strength and modulus, low levels of volatiles, excellent adhesion, low shrinkage, good chemical resistance, and ease of processing. Their major disadvantages are brittleness and the reduction of properties in the presence of moisture. The processing or curing of epoxyes is slower than polyester resins. Processing techniques include autoclave molding, filament winding, press molding, vacuum bag molding, resin transfer molding, and pultrusion. Curing temperatures vary from room temperature to approximately 350 °F (180 °C). The most common cure temperatures range between 250° and 350 °F (120–180 °C). [Figure 7-10]



Figure 7-10. Two part wet layup epoxy resin system with pump dispenser.

Polyimides

Polyimide resins excel in high-temperature environments where their thermal resistance, oxidative stability, low coefficient of thermal expansion, and solvent resistance benefit the design. Their primary uses are circuit boards and hot engine and airframe structures. A polyimide may be either a thermoset resin or a thermoplastic. Polyimides require high cure temperatures, usually in excess of 550 °F (290 °C). Consequently, normal epoxy composite bagging materials are not usable, and steel tooling becomes a necessity. Polyimide bagging and release films, such as Kapton® are used. It is extremely important that Upilex® replace the lower cost nylon bagging and polytetrafluoroethylene (PTFE) release films common to epoxy composite processing. Fiberglass

fabrics must be used for bleeder and breather materials instead of polyester mat materials due to the low melting point of polyester.

Polybenzimidazoles (PBI)

Polybenzimidazole resin is extremely high temperature resistant and is used for high temperature materials. These resins are available as adhesive and fiber.

Bismaleimides (BMI)

Bismaleimide resins have a higher temperature capability and higher toughness than epoxy resins, and they provide excellent performance at ambient and elevated temperatures. The processing of bismaleimide resins is similar to that for epoxy resins. BMIs are used for aero engines and high temperature components. BMIs are suitable for standard autoclave processing, injection molding, resin transfer molding, and sheet molded compound (SMC) among others.

Thermoplastic Resins

Thermoplastic materials can be softened repeatedly by an increase of temperature and hardened by a decrease in temperature. Processing speed is the primary advantage of thermoplastic materials. Chemical curing of the material does not take place during processing, and the material can be shaped by molding or extrusion when it is soft.

Semicrystalline Thermoplastics

Semicrystalline thermoplastics possess properties of inherent flame resistance, superior toughness, good mechanical properties at elevated temperatures and after impact, and low moisture absorption. They are used in secondary and primary aircraft structures. Combined with reinforcing fibers, they are available in injection molding compounds, compression-moldable random sheets, unidirectional tapes, prepregs fabricated from tow (towpreg), and woven prepregs. Fibers impregnated in semicrystalline thermoplastics include carbon, nickel-coated carbon, aramid, glass, quartz, and others.

Amorphous Thermoplastics

Amorphous thermoplastics are available in several physical forms, including films, filaments, and powders. Combined with reinforcing fibers, they are also available in injection molding compounds, compressive moldable random sheets, unidirectional tapes, woven prepregs, etc. The fibers used are primarily carbon, aramid, and glass. The specific advantages of amorphous thermoplastics depend upon the polymer. Typically, the resins are noted for their processing ease and speed, high temperature capability, good mechanical properties, excellent toughness and impact strength,

and chemical stability. The stability results in unlimited shelf life, eliminating the cold storage requirements of thermoset prepregs.

Polyether Ether Ketone (PEEK)

Polyether ether ketone, better known as PEEK, is a high-temperature thermoplastic. This aromatic ketone material offers outstanding thermal and combustion characteristics and resistance to a wide range of solvents and proprietary fluids. PEEK can also be reinforced with glass and carbon.

Curing Stages of Resins

Thermosetting resins use a chemical reaction to cure. There are three curing stages, which are called A, B, and C.

- A stage: The components of the resin (base material and hardener) have been mixed but the chemical reaction has not started. The resin is in the A stage during a wet layup procedure.
- B stage: The components of the resin have been mixed and the chemical reaction has started. The material has thickened and is tacky. The resins of prepreg materials are in the B stage. To prevent further curing the resin is placed in a freezer at 0 °F. In the frozen state, the resin of the prepreg material stays in the B stage. The curing starts when the material is removed from the freezer and warmed again.
- C stage: The resin is fully cured. Some resins cure at room temperature and others need an elevated temperature cure cycle to fully cure.

Pre-impregnated Products (Prepregs)

Prepreg material consists of a combination of a matrix and fiber reinforcement. It is available in unidirectional form (one direction of reinforcement) and fabric form (several directions of reinforcement). All five of the major families of matrix resins can be used to impregnate various fiber forms. The resin is then no longer in a low-viscosity stage, but has been advanced to a B stage level of cure for better handling characteristics. The following products are available in prepreg form: unidirectional tapes, woven fabrics, continuous strand rovings, and chopped mat. Prepreg materials must be stored in a freezer at a temperature below 0 °F to retard the curing process. Prepreg materials are cured with an elevated temperature. Many prepreg materials used in aerospace are impregnated with an epoxy resin and they are cured at either 250 °F or 350 °F. Prepreg materials are cured with an autoclave, oven, or heat blanket. They are typically purchased and stored on a roll in a sealed plastic bag to avoid moisture contamination. [Figure 7-11]

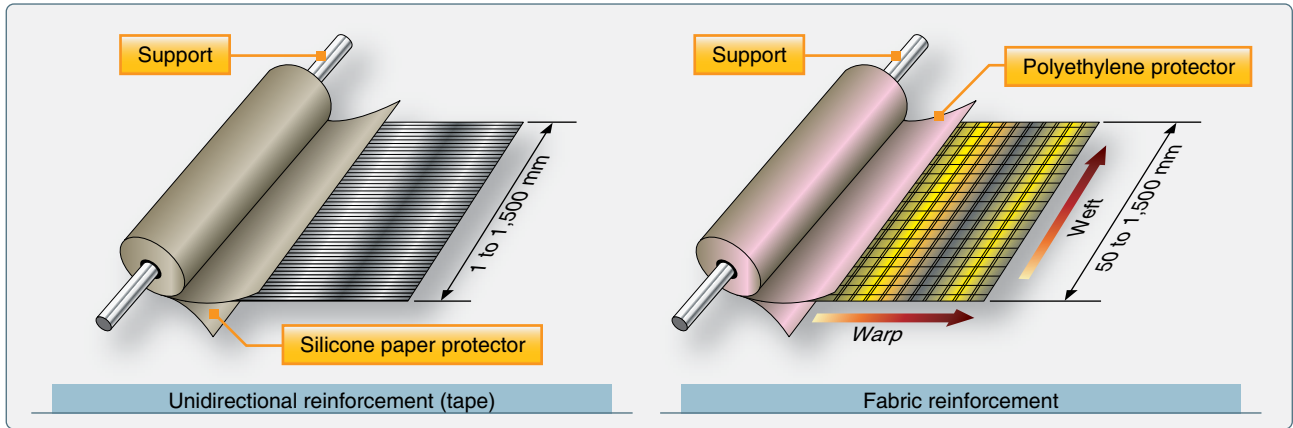

Figure 7-11. Tape and fabric prepreg materials.

Dry Fiber Material

Dry fiber materials, such as carbon, glass, and Kevlar®, are used for many aircraft repair procedures. The dry fabric is impregnated with a resin just before the repair work starts. This process is often called wet layup. The main advantage of using the wet layup process is that the fiber and resin can be stored for a long time at room temperature. The composite can be cured at room temperature or an elevated temperature cure can be used to speed up the curing process and increase the strength. The disadvantage is that the process is messy and reinforcement properties are less than prepreg material properties. [Figure 7-12]



Figure 7-12. Dry fabric materials (top to bottom: aluminum lightning protection mesh, Kevlar®, fiberglass, and carbon fiber).

Thixotropic Agents

Thixotropic agents are gel-like at rest but become fluid when agitated. These materials have high static shear strength and low dynamic shear strength at the same time to lose viscosity under stress.

Adhesives

Film Adhesives

Structural adhesives for aerospace applications are generally supplied as thin films supported on a release paper and stored under refrigerated conditions (-18°C , or 0°F). Film adhesives are available using high temperature aromatic amine or catalytic curing agents with a wide range of flexibilizing and toughening agents. Rubber-toughened epoxy film adhesives are widely used in aircraft industry. The upper temperature limit of $121\text{--}177^{\circ}\text{C}$ ($250\text{--}350^{\circ}\text{F}$) is usually dictated by the degree of toughening required and by the overall choice of resins and curing agents. In general, toughening of a resin results in a lower usable service temperature. Film materials are frequently supported by fibers that serve to improve handling of the films prior to cure, control adhesive flow during bonding, and assist in bond line thickness control. Fibers can be incorporated as short-fiber mats with random orientation or as woven cloth. Commonly encountered fibers are polyesters, polyamides (nylon), and glass. Adhesives containing woven cloth may have slightly degraded environmental properties because of wicking of water by the fiber. Random mat scrim cloth is not as efficient for controlling film thickness as woven cloth because the unrestricted fibers move during bonding. Spunbonded nonwoven scrim do not move and are, therefore, widely used. [Figures 7-13 and 7-14]

Paste Adhesives

Paste adhesives are used as an alternative to film adhesive. These are often used to secondary bond repair patches to damaged parts and also used in places where film adhesive is difficult to apply. Paste adhesives for structural bonding are made mostly from epoxy. One part and two part systems are available. The advantages of paste adhesives are that they can be stored at room temperature and have a long shelf life. The disadvantage is that the bond line thickness is hard to control, which affects the strength of the bond. A scrim

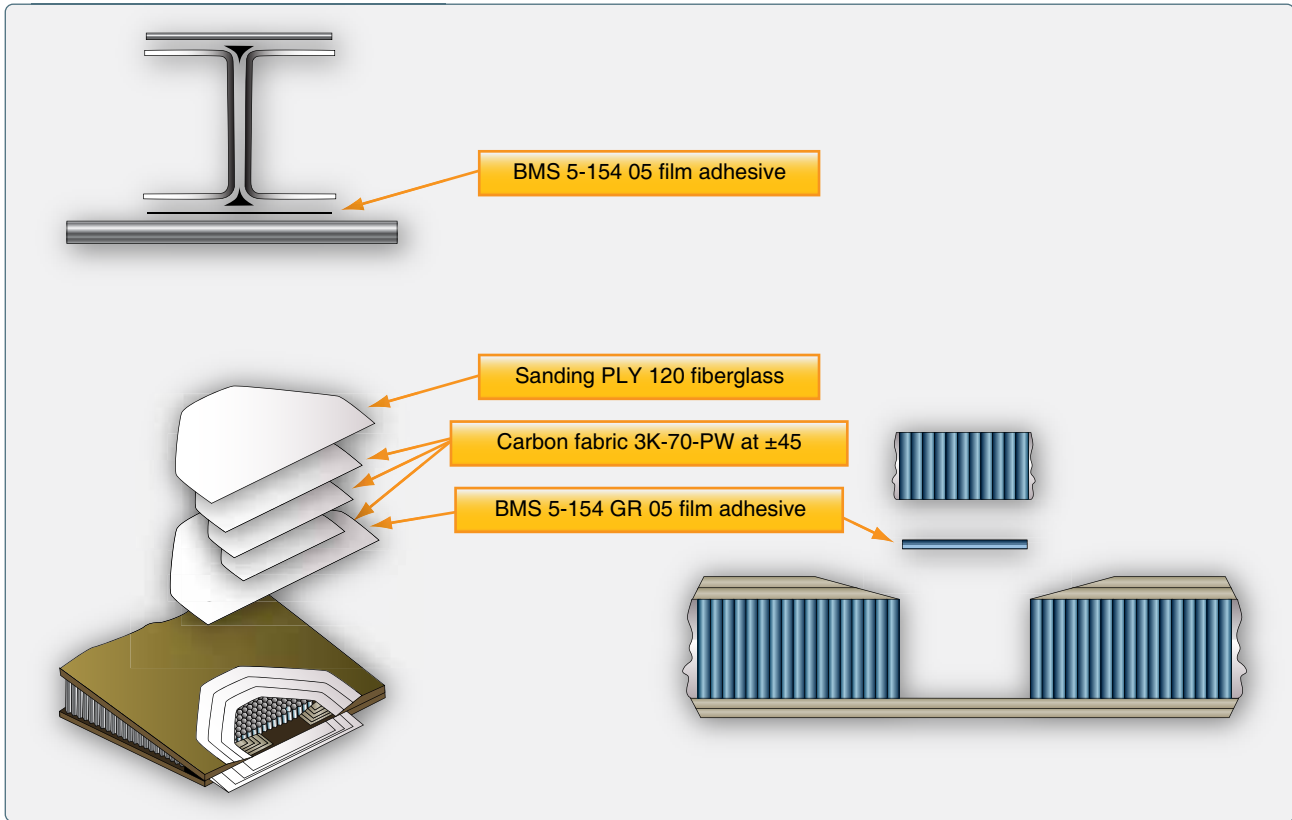

Figure 7-13. The use of film adhesive mess, Kevlar®, fiberglass, and carbon fiber.



Figure 7-14. A roll of film adhesive.



Figure 7-15. Two-part paste adhesive.

cloth can be used to maintain adhesive in the bondline when bonding patches with paste adhesive. [Figure 7-15]

Foaming Adhesives

Most foaming adhesives are 0.025-inch to 0.10-inch thick sheets of B staged epoxy. Foam adhesives cure at 250 °F or 350 °F. During the cure cycle, the foaming adhesives expand. Foaming adhesives need to be stored in the freezer just like preregs, and they have only a limited storage life. Foaming adhesives are used to splice pieces of honeycomb together in a sandwich construction and to bond repair plugs to the existing core during a prepreg repair. [Figure 7-16]

Description of Sandwich Structures

Theory A sandwich construction is a structural panel concept that consists in its simplest form of two relatively thin, parallel face sheets bonded to and separated by a relatively thick, lightweight core. The core supports the face sheets against buckling and resists out-of-plane shear loads. The core must have high shear strength and compression stiffness. Composite sandwich construction is most often fabricated using autoclave cure, press cure, or vacuum bag cure. Skin laminates may be precured and subsequently bonded to core, co-cured to core in one operation, or a combination of the

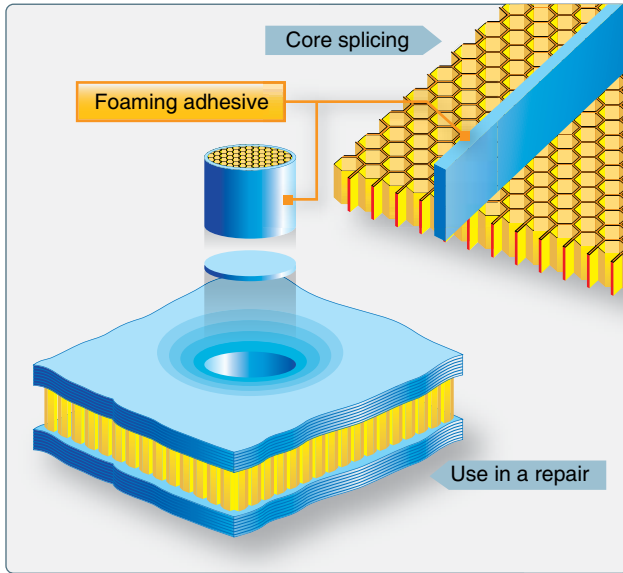

Figure 7-16. The use of foaming adhesives.

two methods. Examples of honeycomb structure are: wing spoilers, fairings, ailerons, flaps, nacelles, floor boards, and rudders. [Figure 7-17]

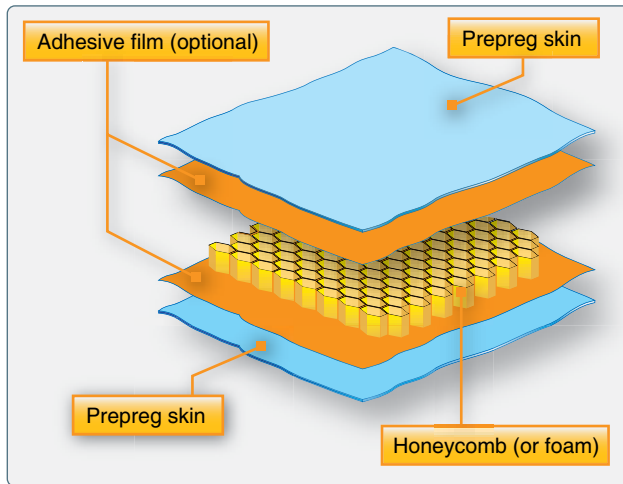

Figure 7-17. Honeycomb sandwich construction.

Properties

Sandwich construction has high bending stiffness at minimal weight in comparison to aluminum and composite laminate construction. Most honeycombs are anisotropic; that is, properties are directional. Figure 7-18 illustrates the advantages of using a honeycomb construction. Increasing the core thickness greatly increases the stiffness of the honeycomb construction, while the weight increase is minimal. Due to the high stiffness of a honeycomb construction, it is not necessary to use external stiffeners, such as stringers and frames. [Figure 7-18]

	Solid Material	Core Thickness t	Core Thickness $3t$
Thickness	1.0	7.0	37.0
Flexural Strength	1.0	3.5	9.2
Weight	1.0	1.03	1.06

Figure 7-18. Strength and stiffness of honeycomb sandwich material compared to a solid laminate.

Facing Materials

Most honeycomb structures used in aircraft construction have aluminum, fiberglass, Kevlar®, or carbon fiber face sheets. Carbon fiber face sheets cannot be used with aluminum honeycomb core material, because it causes the aluminum to corrode. Titanium and steel are used for specialty applications in high temperature constructions. The face sheets of many components, such as spoilers and flight controls, are very thin—sometimes only 3 or 4 plies. Field reports have indicated that these face sheets do not have a good impact resistance.

Core Materials

Honeycomb

Each honeycomb material provides certain properties and has specific benefits. [Figure 7-19] The most common core material used for aircraft honeycomb structures is aramid paper (Nomex® or Korex®). Fiberglass is used for higher strength applications.

- Kraft paper—relatively low strength, good insulating properties, is available in large quantities, and has a low cost.

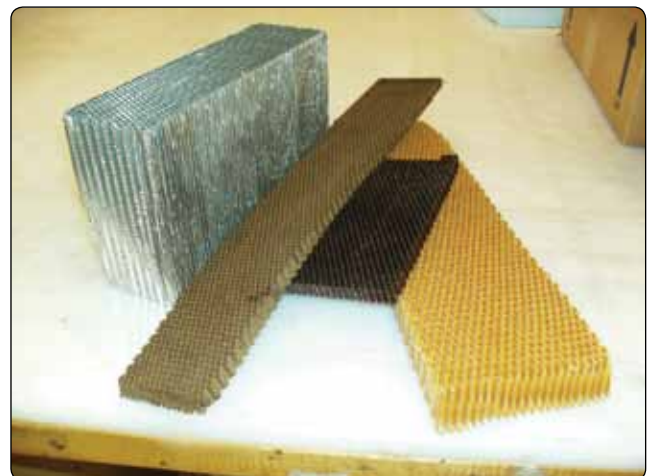

Figure 7-19. Honeycomb core materials.

- Thermoplastics—good insulating properties, good energy absorption and/or redirection, smooth cell walls, moisture and chemical resistance, are environmentally compatible, aesthetically pleasing, and have a relatively low cost.
- Aluminum—best strength-to-weight ratio and energy absorption, has good heat transfer properties, electromagnetic shielding properties, has smooth, thin cell walls, is machinable, and has a relatively low cost.
- Steel—good heat transfer properties, electromagnetic shielding properties, and heat resistant.
- Specialty metals (titanium)—relatively high strength-to-weight ratio, good heat transfer properties, chemical resistance, and heat resistant to very high temperatures.
- Aramid paper—flame resistant, fire retardant, good insulating properties, low dielectric properties, and good formability.
- Fiberglass—tailorable shear properties by layup, low dielectric properties, good insulating properties, and good formability.
- Carbon—good dimensional stability and retention, high-temperature property retention, high stiffness, very low coefficient of thermal expansion, tailorable thermal conductivity, relatively high shear modulus, and very expensive.
- Ceramics—heat resistant to very high temperatures, good insulating properties, is available in very small cell sizes, and very expensive. [Figure 7-19]

Honeycomb core cells for aerospace applications are usually hexagonal. The cells are made by bonding stacked sheets at special locations. The stacked sheets are expanded to form hexagons. The direction parallel to the sheets is called ribbon direction.

Bisected hexagonal core has another sheet of material cutting across each hexagon. Bisected hexagonal honeycomb is stiffer and stronger than hexagonal core. Overexpanded core is made by expanding the sheets more than is needed to make hexagons. The cells of overexpanded core are rectangular. Overexpanded core is flexible perpendicular to the ribbon direction and is used in panels with simple curves. Bell-shaped core, or flexicore, has curved cell walls, that make it flexible in all directions. Bell-shaped core is used in panels with complex curves.

Honeycomb core is available with different cell sizes. Small sizes provide better support for sandwich face sheets. Honeycomb is also available in different densities. Higher density core is stronger and stiffer than lower density core. [Figure 7-20]

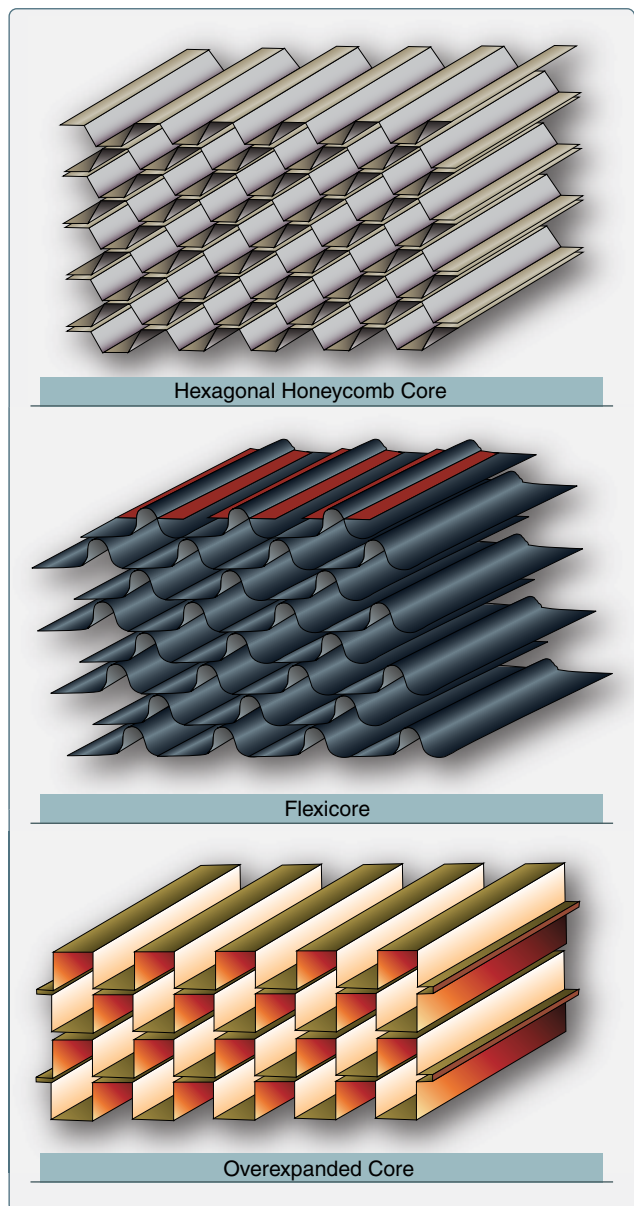

Figure 7-20. Honeycomb density.

Foam

Foam cores are used on homebuilts and lighter aircraft to give strength and shape to wing tips, flight controls, fuselage sections, wings, and wing ribs. Foam cores are not commonly used on commercial type aircraft. Foams are typically heavier than honeycomb and not as strong. A variety of foams can be used as core material including:

- Polystyrene (better known as styrofoam)—aircraft grade styrofoam with a tightly closed cell structure and no voids between cells; high compressive strength and good resistance to water penetration; can be cut with a hot wire to make airfoil shapes.

- Phenolic—very good fire-resistant properties and can have very low density, but relatively low mechanical properties.
- Polyurethane—used for producing the fuselage, wing tips, and other curved parts of small aircraft; relatively inexpensive, fuel resistant, and compatible with most adhesives; do not use a hot wire to cut polyurethane foam; easily contoured with a large knife and sanding equipment.
- Polypropylene—used to make airfoil shapes; can be cut with a hot wire; compatible with most adhesives and epoxy resins; not for use with polyester resins, dissolves in fuels and solvents.
- Polyvinyl chloride (PVC) (Divinycell, Klegecell, and Airex)—a closed cell medium- to high-density foam with high compression strength, durability, and excellent fire resistance; can be vacuum formed to compound shapes and be bent using heat; compatible with polyester, vinyl ester, and epoxy resins.
- Polymethacrylimide (Rohacell)—a closed-cell foam used for lightweight sandwich construction; excellent mechanical properties, high dimensional stability under heat, good solvent resistance, and outstanding creep compression resistance; more expensive than the other types of foams, but has greater mechanical properties.

Balsa Wood

Balsa is a natural wood product with elongated closed cells; it is available in a variety of grades that correlate to the structural, cosmetic, and physical characteristics. The density of balsa is less than one-half of the density of conventional wood products. However, balsa has a considerably higher density than the other types of structural cores.

Manufacturing and In-Service Damage

Manufacturing Defects

Manufacturing defects include:

- Delamination
- Resin starved areas
- Resin rich areas
- Blisters, air bubbles
- Wrinkles
- Voids
- Thermal decomposition

Manufacturing damage includes anomalies, such as porosity, microcracking, and delaminations resulting from processing discrepancies. It also includes such items as inadvertent

edge cuts, surface gouges and scratches, damaged fastener holes, and impact damage. Examples of flaws occurring in manufacturing include a contaminated bondline surface or inclusions, such as prepreg backing paper or separation film, that is inadvertently left between plies during layup. Inadvertent (nonprocess) damage can occur in detail parts or components during assembly or transport or during operation.

A part is resin rich if too much resin is used, for nonstructural applications this is not necessarily bad, but it adds weight. A part is called resin starved if too much resin is bled off during the curing process or if not enough resin is applied during the wet layup process. Resin-starved areas are indicated by fibers that show to the surface. The ratio of 60:40 fiber to resin ratio is considered optimum. Sources of manufacturing defects include:

- Improper cure or processing
- Improper machining
- Mishandling
- Improper drilling
- Tool drops
- Contamination
- Improper sanding
- Substandard material
- Inadequate tooling
- Mislocation of holes or details

Damage can occur at several scales within the composite material and structural configuration. This ranges from damage in the matrix and fiber to broken elements and failure of bonded or bolted attachments. The extent of damage controls repeated load life and residual strength and is critical to damage tolerance.

Fiber Breakage

Fiber breakage can be critical because structures are typically designed to be fiber dominant (i.e., fibers carry most of the loads). Fortunately, fiber failure is typically limited to a zone near the point of impact and is constrained by the impact object size and energy. Only a few of the service-related events listed in the previous section could lead to large areas of fiber damage.

Matrix Imperfections

Matrix imperfections usually occur on the matrix-fiber interface or in the matrix parallel to the fibers. These imperfections can slightly reduce some of the material properties but are seldom critical to the structure, unless the matrix degradation is widespread. Accumulation of matrix

cracks can cause the degradation of matrix-dominated properties. For laminates designed to transmit loads with their fibers (fiber dominant), only a slight reduction of properties is observed when the matrix is severely damaged. Matrix cracks, or microcracks, can significantly reduce properties dependent on the resin or the fiber-resin interface, such as interlaminar shear and compression strength. Micro-cracking can have a very negative effect on properties of high-temperature resins. Matrix imperfections may develop into delaminations, which are a more critical type of damage.

Delamination and Debonds

Delaminations form on the interface between the layers in the laminate. Delaminations may form from matrix cracks that grow into the interlaminar layer or from low-energy impact. Debonds can also form from production nonadhesion along the bondline between two elements and initiate delamination in adjacent laminate layers. Under certain conditions, delaminations or debonds can grow when subjected to repeated loading and can cause catastrophic failure when the laminate is loaded in compression. The criticality of delaminations or debonds depend on:

- Dimensions.
- Number of delaminations at a given location.
- Location—in the thickness of laminate, in the structure, proximity to free edges, stress concentration region, geometrical discontinuities, etc.
- Loads—behavior of delaminations and debonds depend on loading type. They have little effect on the response of laminates loaded in tension. Under compression or shear loading, however, the sublaminates adjacent to the delaminations or debonded elements may buckle and cause a load redistribution mechanism that leads to structural failure.

Combinations of Damages

In general, impact events cause combinations of damages. High-energy impacts by large objects (e.g., turbine blades) may lead to broken elements and failed attachments. The resulting damage may include significant fiber failure, matrix cracking, delamination, broken fasteners, and debonded elements. Damage caused by low-energy impact is more contained, but may also include a combination of broken fibers, matrix cracks, and multiple delaminations.

Flawed Fastener Holes

Improper hole drilling, poor fastener installation, and missing fasteners may occur in manufacturing. Hole elongation can occur due to repeated load cycling in service.

In-Service Defects

In-service defects include:

- Environmental degradation
- Impact damage
- Fatigue
- Cracks from local overload
- Debonding
- Delamination
- Fiber fracturing
- Erosion

Many honeycomb structures, such as wing spoilers, fairings, flight controls, and landing gear doors, have thin face sheets which have experienced durability problems that could be grouped into three categories: low resistance to impact, liquid ingress, and erosion. These structures have adequate stiffness and strength but low resistance to a service environment in which parts are crawled over, tools dropped, and service personnel are often unaware of the fragility of thin-skinned sandwich parts. Damages to these components, such as core crush, impact damages, and disbonds, are quite often easy to detect with a visual inspection due to their thin face sheets. However, they are sometimes overlooked or damaged by service personnel who do not want to delay aircraft departure or bring attention to their accidents, which might reflect poorly on their performance record. Therefore, damages are sometimes allowed to go unchecked, often resulting in growth of the damage due to liquid ingress into the core. Nondurable design details (e.g., improper core edge close-outs) also lead to liquid ingress.

The repair of parts due to liquid ingress can vary depending on the liquid, most commonly water or Skydrol (hydraulic fluid). Water tends to create additional damage in repaired parts when cured unless all moisture is removed from the part. Most repair material systems cure at temperatures above the boiling point of water, which can cause a disbond at the skin-to-core interface wherever trapped water resides. For this reason, core drying cycles are typically included prior to performing any repair. Some operators take the extra step of placing a damaged but unrepaired part in the autoclave to dry to preclude any additional damage from occurring during the cure of the repair. Skydrol presents a different problem. Once the core of a sandwich part is saturated, complete removal of Skydrol is almost impossible. The part continues to weep the liquid even in cure until bondlines can become contaminated and full bonding does not occur. Removal of contaminated core and adhesive as part of the repair is highly recommended. [Figure 7-21]



Figure 7-21. *Damage to radome honeycomb sandwich structure.*

Erosion capabilities of composite materials have been known to be less than that of aluminum and, as a result, their application in leading-edge surfaces has been generally avoided. However, composites have been used in areas of highly complex geometry, but generally with an erosion coating. The durability and maintainability of some erosion coatings are less than ideal. Another problem, not as obvious as the first, is that edges of doors or panels can erode if they are exposed to the air stream. This erosion can be attributed to improper design or installation/fit-up. On the other hand, metal structures in contact or in the vicinity of these composite parts may show corrosion damage due to inappropriate choice of aluminum alloy, damaged corrosion sealant of metal parts during assembly or at splices, or insufficient sealant and/or lack of glass fabric isolation plies at the interfaces of spars, ribs, and fittings. [Figure 7-22]

Corrosion

Many fiberglass and Kevlar® parts have a fine aluminum mesh for lightning protection. This aluminum mesh often corrodes around the bolt or screw holes. The corrosion affects the electrical bonding of the panel, and the aluminum mesh needs to be removed and new mesh installed to restore the electrical bonding of the panel. [Figure 7-23]

Ultraviolet (UV) light affects the strength of composite materials. Composite structures need to be protected by a top coating to prevent the effects of UV light. Special UV primers and paints have been developed to protect composite materials.

Nondestructive Inspection (NDI) of Composites

Visual Inspection

A visual inspection is the primary inspection method for in-service inspections. Most types of damage scorch, stain, dent, penetrate, abrade, or chip the composite surface, making the damage visible. Once damage is detected, the affected area needs to be inspected closer using flashlights, magnifying glasses, mirrors, and borescopes. These tools are used to magnify defects that otherwise might not be seen easily and to allow visual inspection of areas that are not readily accessible. Resin starvation, resin richness, wrinkles, ply bridging, discoloration (due to overheating, lightning strike, etc.), impact damage by any cause, foreign matter, blisters, and disbonding are some of the discrepancies that can be detected with a visual inspection. Visual inspection cannot find internal flaws in the composite, such as delaminations, disbonds, and matrix crazing. More sophisticated NDI techniques are needed to detect these types of defects.



Figure 7-22. *Erosion damage to wingtip.*

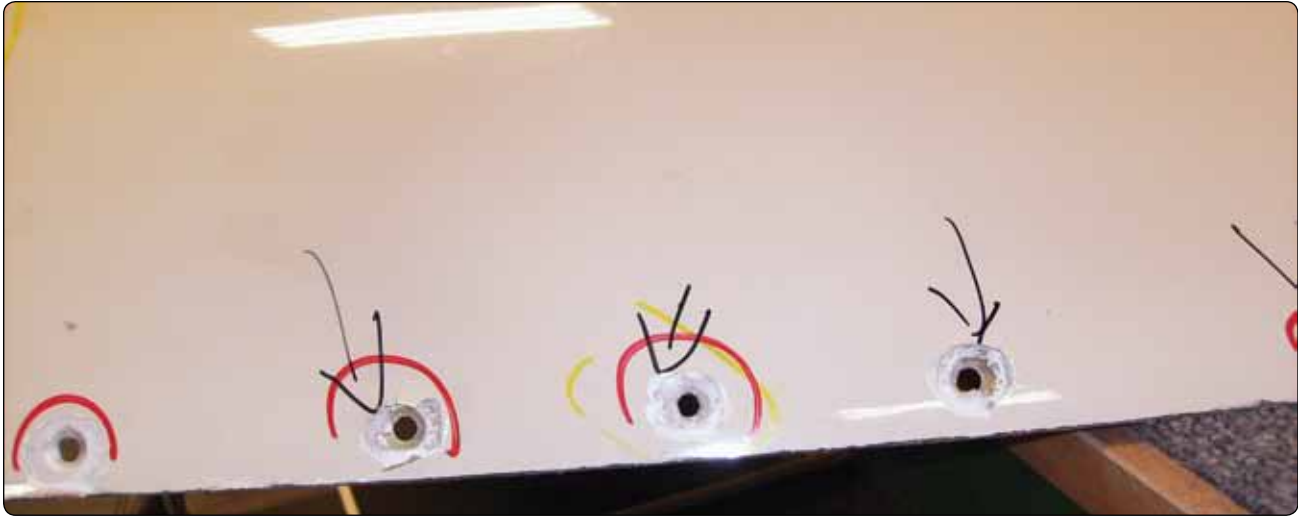

Figure 7-23. Corrosion of aluminum lightning protection mesh.

Audible Sonic Testing (Coin Tapping)

Sometimes referred to as audio, sonic, or coin tap, this technique makes use of frequencies in the audible range (10 Hz to 20 Hz). A surprisingly accurate method in the hands of experienced personnel, tap testing is perhaps the most common technique used for the detection of delamination and/or disbond. The method is accomplished by tapping the inspection area with a solid round disk or lightweight hammer-like device and listening to the response of the structure to the hammer. [Figure 7-24] A clear, sharp, ringing sound is indicative of a well-bonded solid structure, while a dull or thud-like sound indicates a discrepant area.

The tapping rate needs to be rapid enough to produce enough sound for any difference in sound tone to be discernable to the ear. Tap testing is effective on thin skin to stiffener bondlines, honeycomb sandwich with thin face sheets, or even near the surface of thick laminates, such as rotorcraft blade

supports. Again, inherent in the method is the possibility that changes within the internal elements of the structure might produce pitch changes that are interpreted as defects, when in fact they are present by design. This inspection should be accomplished in as quiet an area as possible and by experienced personnel familiar with the part's internal configuration. This method is not reliable for structures with more than four plies. It is often used to map out the damage on thin honeycomb facesheets. [Figure 7-24]

Automated Tap Test

This test is very similar to the manual tap test except that a solenoid is used instead of a hammer. The solenoid produces multiple impacts in a single area. The tip of the impactor has a transducer that records the force versus time signal of the impactor. The magnitude of the force depends on the impactor, the impact energy, and the mechanical properties of the structure. The impact duration (period) is not sensitive

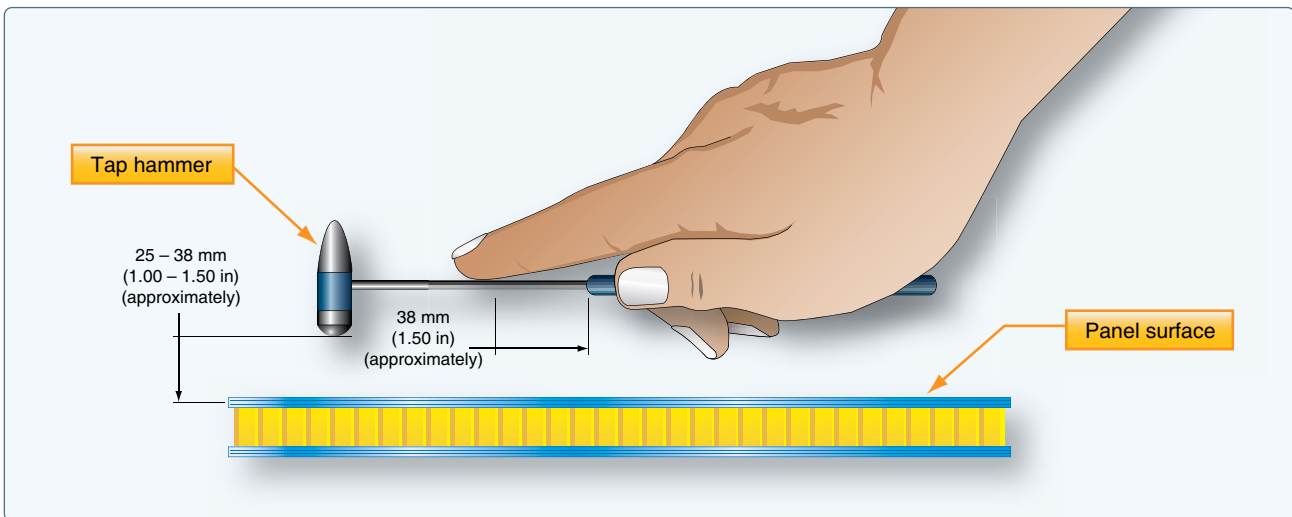

Figure 7-24. Tap test with tap hammer.

to the magnitude of the impact force; however, this duration changes as the stiffness of the structure is altered. Therefore, the signal from an unflawed region is used for calibration, and any deviation from this unflawed signal indicates the existence of damage.

Ultrasonic Inspection

Ultrasonic inspection has proven to be a very useful tool for the detection of internal delaminations, voids, or inconsistencies in composite components not otherwise discernable using visual or tap methodology. There are many ultrasonic techniques; however, each technique uses sound wave energy with a frequency above the audible range. [Figure 7-25] A high-frequency (usually several MHz) sound wave is introduced into the part and may be directed to travel normal to the part surface, or along the surface of the part, or at some predefined angle to the part surface. You may need to try different directions to locate the flow. The introduced sound is then monitored as it travels its assigned route through the part for any significant change. Ultrasonic sound waves have properties similar to light waves. When an ultrasonic wave strikes an interrupting object, the wave or energy is either absorbed or reflected back to the surface. The disrupted or diminished sonic energy is then picked up by a receiving transducer and converted into a display on an oscilloscope or a chart recorder. The display allows the operator to evaluate

the discrepant indications comparatively with those areas known to be good. To facilitate the comparison, reference standards are established and utilized to calibrate the ultrasonic equipment.

The repair technician must realize that the concepts outlined here work fine in the repetitious manufacturing environment, but are likely to be more difficult to implement in a repair environment given the vast number of different composite components installed on the aircraft and the relative complexity of their construction. The reference standards would also have to take into account the transmutations that take place when a composite component is exposed to an in-service environment over a prolonged period or has been the subject of repair activity or similar restorative action. The four most common ultrasonic techniques are discussed next.

Through Transmission Ultrasonic Inspection

Through transmission ultrasonic inspection uses two transducers, one on each side of the area to be inspected. The ultrasonic signal is transmitted from one transducer to the other transducer. The loss of signal strength is then measured by the instrument. The instrument shows the loss as a percent of the original signal strength or the loss in decibels. The signal loss is compared to a reference standard. Areas with a greater loss than the reference standard indicate a defective area.

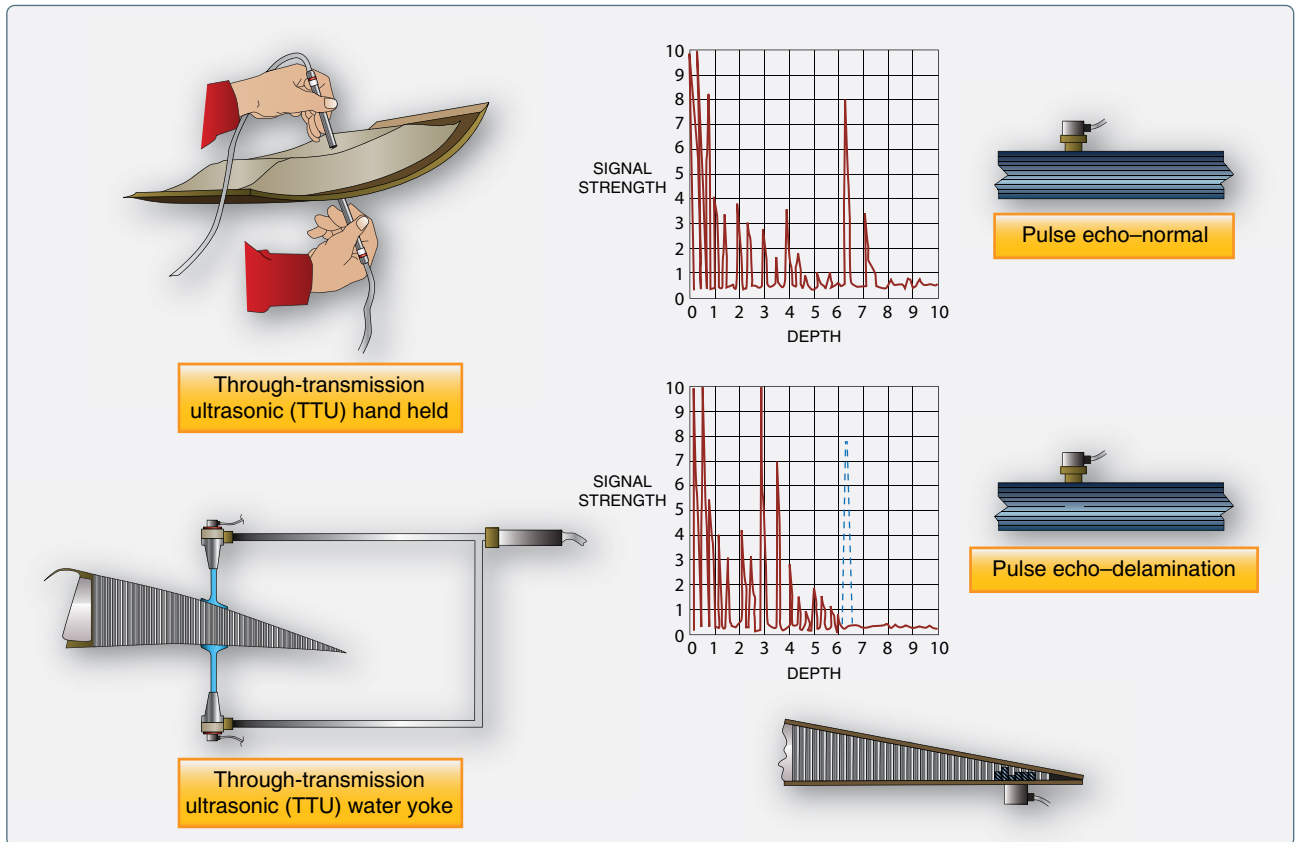

Figure 7-25. Ultrasonic testing methods.

Pulse Echo Ultrasonic Inspection

Single-side ultrasonic inspection may be accomplished using pulse echo techniques. In this method, a single search unit is working as a transmitting and a receiving transducer that is excited by high voltage pulses. Each electrical pulse activates the transducer element. This element converts the electrical energy into mechanical energy in the form of an ultrasonic sound wave. The sonic energy travels through a Teflon® or methacrylate contact tip into the test part. A waveform is generated in the test part and is picked up by the transducer element. Any change in amplitude of the received signal, or time required for the echo to return to the transducer, indicates the presence of a defect. Pulse echo inspections are used to find delaminations, cracks, porosity, water, and disbands of bonded components. Pulse echo does not find disbands or defects between laminated skins and honeycomb core. [Figure 7-26]



Figure 7-26. *Pulse echo test equipment.*

Ultrasonic Bondtester Inspection

Low-frequency and high-frequency bondtesters are used for ultrasonic inspections of composite structures. These bondtesters use an inspection probe that has one or two transducers. The high-frequency bondtester is used to detect delaminations and voids. It cannot detect a skin-to-honeycomb core disbond or porosity. It can detect defects as small as 0.5-inch in diameter. The low-frequency bondtester uses two transducers and is used to detect delamination,

voids, and skin to honeycomb core disbands. This inspection method does not detect which side of the part is damaged, and cannot detect defects smaller than 1.0-inch. [Figure 7-27]



Figure 7-27. *Bond tester.*

Phased Array Inspection

Phased array inspection is one of the latest ultrasonic instruments to detect flaws in composite structures. It operates under the same principle of operation as pulse echo, but it uses 64 sensors at the same time, which speeds up the process. [Figure 7-28]



Figure 7-28. *Phased array testing equipment.*

Radiography

Radiography, often referred to as X-ray, is a very useful NDI method because it essentially allows a view into the interior of the part. This inspection method is accomplished by passing X-rays through the part or assembly being tested while recording the absorption of the rays onto a film sensitive to X-rays. The exposed film, when developed, allows the inspector to analyze variations in the opacity of the exposure recorded onto the film, in effect creating a visualization of the relationship of the component's internal details. Since the method records changes in total density through its thickness, it is not a preferred method for detecting defects such as delaminations that are in a plane that is normal to the ray direction. It is a most effective method, however, for detecting flaws parallel to the X-ray beam's centerline. Internal anomalies, such as delaminations in the corners, crushed core, blown core, water in core cells, voids in foam adhesive joints, and relative position of internal details, can readily be seen via radiography. Most composites are nearly transparent to X-rays, so low energy rays must be used. Because of safety concerns, it is impractical to use around aircraft. Operators should always be protected by sufficient lead shields, as the possibility of exposure exists either from the X-ray tube or from scattered radiation. Maintaining a minimum safe distance from the X-ray source is always essential.

Thermography

Thermal inspection comprises all methods in which heat-sensing devices are used to measure temperature variations for parts under inspection. The basic principle of thermal inspection consists of measuring or mapping of surface temperatures when heat flows from, to, or through a test object. All thermographic techniques rely on differentials in thermal conductivity between normal, defect free areas, and those having a defect. Normally, a heat source is used to elevate the temperature of the part being examined while observing the surface heating effects. Because defect free areas conduct heat more efficiently than areas with defects, the amount of heat that is either absorbed or reflected indicates the quality of the bond. The type of defects that affect the thermal properties include debonds, cracks, impact damage, panel thinning, and water ingress into composite materials and honeycomb core. Thermal methods are most effective for thin laminates or for defects near the surface.

Neutron Radiography

Neutron radiography is a nondestructive imaging technique that is capable of visualizing the internal characteristics of a sample. The transmission of neutrons through a medium is dependent upon the neutron cross sections for the nuclei in the medium. Differential attenuation of neutrons through a medium may be measured, mapped, and then visualized.

The resulting image may then be utilized to analyze the internal characteristics of the sample. Neutron radiography is a complementary technique to X-ray radiography. Both techniques visualize the attenuation through a medium. The major advantage of neutron radiography is its ability to reveal light elements such as hydrogen found in corrosion products and water.

Moisture Detector

A moisture meter can be used to detect water in sandwich honeycomb structures. A moisture meter measures the RF power loss caused by the presence of water. The moisture meter is often used to detect moisture in nose radomes. [Figure 7-29] Figure 7-30 provides a comparison of NDI testing equipment.



Figure 7-29. Moisture tester equipment.

Composite Repairs

Layup Materials

Hand Tools

Prepreg and dry fabrics can be cut with hand tools, such as scissors, pizza cutters, and knives. Materials made from Kevlar® are more difficult to cut than fiberglass or carbon and tools wear quicker. A squeegee and a brush are used to impregnate dry fibers with resin for wet layup. Markers, rulers, and circle templates are used to make a repair layout. [Figure 7-31]

Method of Inspection	Type of Defect							
	Disbond	Delamination	Dent	Crack	Hole	Water Ingestion	Overheat and Burns	Lightning Strike
Visual	X (1)	X (1)	X	X	X		X	X
X-Ray	X (1)	X (1)		X (1)		X		
Ultrasonic TTU	X	X						
Ultrasonic pulse echo		X				X		
Ultrasonic bondtester	X	X						
Tap test	X (2)	X (2)						
Infrared thermography	X (3)	X (3)				X		
Dye penetrant				X (4)				
Eddy current				X (4)				
Shearography	X (3)	X (3)						

Notes: (1) For defects that open to the surface
(2) For thin structure (3 plies or less)
(3) The procedures for this type of inspection are being developed
(4) This procedure is not recommended

Figure 7-30. Comparison of NDI testing equipment.



Figure 7-31. Hand tools for laminating.



Figure 7-32. Air tools used for composite repair.

Air Tools

Air-driven power tools, such as drill motors, routers, and grinders, are used for composite materials. Electric motors are not recommended, because carbon is a conductive material that can cause an electrical short circuit. If electric tools are used, they need to be of the totally enclosed type. [Figure 7-32]

Caul Plate

A caul plate made from aluminum is often used to support the part during the cure cycle. A mold release agent, or parting film, is applied to the caul plate so that the part does not attach to the caul plate. A thin caul plate is also used on top of the repair when a heat bonder is used. The caul plate provides a more uniform heated area and it leaves a smoother finish of the composite laminate.

Support Tooling and Molds

Certain repairs require tools to support the part and/or maintain surface contour during cure. A variety of materials can be used to manufacture these tools. The type of material depends on the type of repair, cure temperature, and whether it is a temporary or permanent tool. Support tooling is necessary for oven and autoclave cure due to the high cure temperature. The parts deform if support tooling is not used. There are many types of tooling material available. Some are molded to a specific part contour and others are used as rigid supports to maintain the contour during cure. Plaster is an inexpensive and easy material for contour tooling. It can be filled with fiberglass, hemp, or other material. Plaster is not very durable, but can be used for temporary tools. Often, a layer of fiberglass-reinforced epoxy is placed on the tool side surface to improve the finish quality. Tooling resins are used

to impregnate fiberglass, carbon fiber, or other reinforcements to make permanent tools. Complex parts are made from metal or high-temperature tooling boards that are machined with 5-axis CNC equipment to make master tools that can be used to fabricate aircraft parts. [Figures 7-33 and 7-34]



Figure 7-33. Five-axis CNC equipment for tool and mold making.



Figure 7-34. A mold of an inlet duct.

Vacuum Bag Materials

Repairs of composite aircraft components are often performed with a technique known as vacuum bagging. A plastic bag is sealed around the repair area. Air is then removed from the bag, which allows repair plies to be drawn together with no air trapped in between. Atmospheric pressure bears on the repair and a strong, secure bond is created.

Several processing materials are used for vacuum bagging a part. These materials do not become part of the repair and are discarded after the repair process.

Release Agents

Release agents, also called mold release agents, are used so that the part comes off the tool or caul plate easily after curing.

Bleeder Ply

The bleeder ply creates a path for the air and volatiles to escape from the repair. Excess resin is collected in the bleeder. Bleeder material could be made of a layer of fiberglass, nonwoven polyester, or it could be a perforated Teflon[®] coated material. The structural repair manual (SRM) indicates what type and how many plies of bleeder are required. As a general rule, the thicker the laminate, the more bleeder plies are required.

Peel Ply

Peel plies are often used to create a clean surface for bonding purposes. A thin layer of fiberglass is cured with the repair part. Just before the part is bonded to another structure, the peel ply is removed. The peel ply is easy to remove and leaves a clean surface for bonding. Peel plies are manufactured from polyester, nylon, fluorinated ethylene propylene (FEP), or coated fiberglass. They can be difficult to remove if overheated. Some coated peel plies can leave an undesirable contamination on the surface. The preferred peel ply material is polyester that has been heat-set to eliminate shrinkage.

Layup Tapes

Vacuum bag sealing tape, also called sticky tape, is used to seal the vacuum bag to the part or tool. Always check the temperature rating of the tape before use to ensure that you use appropriately rated tape.

Perforated Release Film

Perforated parting film is used to allow air and volatiles out of the repair, and it prevents the bleeder ply from sticking to the part or repair. It is available with different size holes and hole spacing depending on the amount of bleeding required.

Solid Release Film

Solid release films are used so that the prepreg or wet layup plies do not stick to the working surface or caul plate. Solid release film is also used to prevent the resins from bleeding through and damaging the heat blanket or caul plate if they are used.

Breather Material

The breather material is used to provide a path for air to get out of the vacuum bag. The breather must contact the bleeder. Typically, polyester is used in either 4-ounce or 10-ounce weights. Four ounces is used for applications below 50 pounds per square inch (psi) and 10 ounces is used for 50–100 psi.

Vacuum Bag

The vacuum bag material provides a tough layer between the repair and the atmosphere. The vacuum bag material

is available in different temperature ratings, so make sure that the material used for the repair can handle the cure temperature. Most vacuum bag materials are one time use, but material made from flexible silicon rubber is reusable. Two small cuts are made in the bagging material so that the vacuum probe valve can be installed. The vacuum bag is not very flexible and plies need to be made in the bag if complex shapes are to be bagged. Sometimes, an envelope type bag is used, but the disadvantage of this method is that the vacuum pressure might crush the part. Reusable bags made from silicon rubber are available that are more flexible. Some have a built-in heater blanket that simplifies the bagging task. [Figures 7-35, 7-36, and 7-37]



Figure 7-35. Bagging materials.



Figure 7-36. Bagging of complex part.

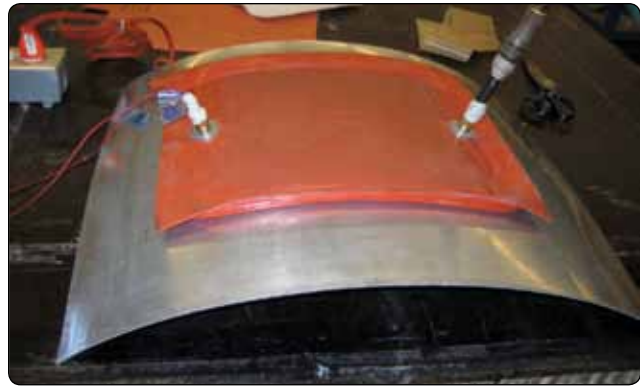

Figure 7-37. Self-sealing vacuum bag with heater element.

Vacuum Equipment

A vacuum pump is used to evacuate air and volatiles from the vacuum bag so that atmospheric pressure consolidates the plies. A dedicated vacuum pump is used in a repair shop. For repairs on the aircraft, a mobile vacuum pump could be used. Most heat bonders have a built-in vacuum pump. Special air hoses are used as vacuum lines, because regular air hoses might collapse when a vacuum is applied. The vacuum lines that are used in the oven or autoclave need to be able to withstand the high temperatures in the heating device. A vacuum pressure regulator is sometimes used to lower the vacuum pressure during the bagging process.

Vacuum Compaction Table

A vacuum compaction table is a convenient tool for debulking composite layups with multiple plies. Essentially a reusable vacuum bag, a compaction table consists of a metal table surface with a hinged cover. The cover includes a solid frame, a flexible membrane, and a vacuum seal. Repair plies are laid up on the table surface and sealed beneath the cover with vacuum to remove entrapped air. Some compaction tables are heated but most are not.

Heat Sources

Oven

Composite materials can be cured in ovens using various pressure application methods. [Figure 7-38] Typically, vacuum bagging is used to remove volatiles and trapped air and utilizes atmospheric pressure for consolidation. Another method of pressure application for oven cures is the use of shrink wrapping or shrink tape. The oven uses heated air circulated at high speed to cure the material system. Typical oven cure temperatures are 250 °F and 350 °F. Ovens have a temperature sensor to feed temperature data back to the oven controller. The oven temperature can differ from the actual part temperature depending upon the location of the oven sensor and the location of the part in the oven. The thermal mass of the part in the oven is generally greater



Figure 7-38. Walk-in curing oven.

than the surrounding oven and during rise to temperature, the part temperature can lag the oven temperature by a considerable amount. To deal with these differences, at least two thermocouples must be placed on the part and connected to a temperature-sensing device (separate chart recorder, hot bonder, etc.) located outside the oven. Some oven controllers can be controlled by thermocouples placed on the repair part.

Autoclave

An autoclave system allows a complex chemical reaction to occur inside a pressure vessel according to a specified time, temperature, and pressure profile in order to process a variety of materials. [Figure 7-39] The evolution of materials and processes has taken autoclave operating conditions from

120 °C (250 °F) and 275 kPa (40 psi) to well over 760 °C (1,400 °F) and 69,000 kPa (10,000 psi). Autoclaves that are operated at lower temperatures and pressures can be pressurized by air, but if higher temperatures and pressures are required for the cure cycle, a 50/50 mixture of air and nitrogen or 100 percent nitrogen should be used to reduce the change of an autoclave fire.

The major elements of an autoclave system are a vessel to contain pressure, sources to heat the gas stream and circulate it uniformly within the vessel, a subsystem to apply vacuum to parts covered by a vacuum bag, a subsystem to control operating parameters, and a subsystem to load the molds into the autoclave. Modern autoclaves are computer controlled and the operator can write and monitor all types of cure cycle programs. The most accurate way to control the cure cycle is to control the autoclave controller with thermocouples that are placed on the actual part.

Most parts processed in autoclaves are covered with a vacuum bag that is used primarily for compaction of laminates and to provide a path for removal of volatiles. The bag allows the part to be subjected to differential pressure in the autoclave without being directly exposed to the autoclave atmosphere. The vacuum bag is also used to apply varying levels of vacuum to the part.

Heat Bonder and Heat Lamps

Typical on-aircraft heating methods include electrical resistance heat blankets, infrared heat lamps, and hot air devices. All heating devices must be controlled by some means so that the correct amount of heat can be applied. This is particularly important for repairs using prepreg material and adhesives, because controlled heating and cooling rates are usually prescribed.



Figure 7-39. Autoclave.

Heat Bonder

A heat bonder is a portable device that automatically controls heating based on temperature feedback from the repair area. Heat bonders also have a vacuum pump that supplies and monitors the vacuum in the vacuum bag. The heat bonder controls the cure cycle with thermocouples that are placed near the repair. Some repairs require up to 10 thermocouples. Modern heat bonders can run many different types of cure programs and cure cycle data can be printed out or uploaded to a computer. [Figure 7-40]



Figure 7-40. Heat bonder equipment.

Heat Blanket

A heat blanket is a flexible heater. It is made of two layers of silicon rubber with a metal resistance heater between the two layers of silicon. Heat blankets are a common method of applying heat for repairs on the aircraft. Heat blankets may be controlled manually; however, they are usually used in conjunction with a heat bonder. Heat is transferred from the blanket via conduction. Consequently, the heat blanket must conform to and be in 100 percent contact with the part, which is usually accomplished using vacuum bag pressure. [Figure 7-41]

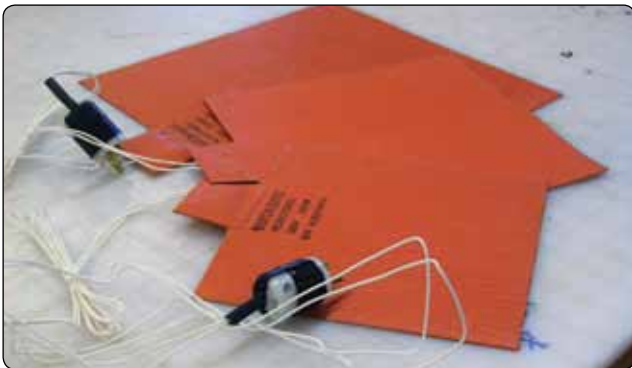

Figure 7-41. Heat blankets.

Heat Lamp

Infrared heat lamps can also be used for elevated temperature curing of composites if a vacuum bag is not utilized. However, they are generally not effective for producing curing temperatures above 150 °F, or for areas larger than two square feet. It is also difficult to control the heat applied with a lamp, and lamps tend to generate high-surface temperatures quickly. If controlled by thermostats, heat lamps can be useful in applying curing heat to large or irregular surfaces. Heat bonders can be used to control heat lamps.

Hot Air System

Hot air systems can be used to cure composite repairs, and are mainly restricted to small repairs and for drying the repair area. A heat generator supplies hot air that is directed into an insulated enclosure set up around the repair area after vacuum bagging has been deployed. The hot air surrounds the repair for even temperature rise.

Heat Press Forming

During the press forming process, flat stacked thermoplastic prepreg is heated to above melt temperature (340–430 °C, or 645–805 °F) in an oven, rapidly (1-10 seconds) shuttled to a forming die, pressed to shape, and consolidated and cooled under pressure (700–7,000 kPa, or 100–1,000 psi). [Figure 7-42] In production, press forming dies usually are matched male-female sets constructed of steel or aluminum. However, rubber, wood, phenolics, and so on can be used during prototyping. The die set can be maintained at room temperature throughout the forming-consolidation cycle. But, the use of a hot die (120–200 °C, or 250–390 °F) allows control of the cooling-down rate (avoiding part warpage and controlling morphology in semicrystalline thermoplastic prepreg, such as PEEK and polyphenylene sulfide) and extends the forming window promoting better ply slip.



Figure 7-42. Heat press.

The main disadvantage with this method is that the press only applies pressure in one direction, and hence, it is difficult to make complex-shaped (e.g., beads, closed corners) parts or parts with legs that approach vertical. Since the temperature of the die set need not be cycled with each part, rapid forming times of between 10 minutes and 2 hours are achievable with press forming.

Thermocouples

A thermocouple (TC) is a thermoelectric device used to accurately measure temperatures. It may be connected to a simple temperature reading device, or connected to a hot bonder, oven, or other type of controller that regulates the amount of heat. TCs consist of a wire with two leads of dissimilar metals that are joined at one end. Heating the joint produces an electric current, which is converted to a temperature reading with a TC monitor. Select the type of wire (J or K) and the type of connector that are compatible with the local temperature monitoring equipment (hot bonder, oven, autoclave, etc.). TC wire is available with different types of insulation; check the manufacturer's product data sheets to ensure the insulation withstands the highest cure temperature. Teflon-insulated wire is generally good for 390 °F and lower cures; Kapton-insulated wire should be used for higher temperatures.

Thermocouple Placement

Thermocouple placement is the key in obtaining proper cure temperatures throughout the repair. In general, the thermocouples used for temperature control should be placed as close as possible to the repair material without causing it to become embedded in the repair or producing indentations in the repair. They should also be placed in strategic hot or cold locations to ensure the materials are adequately cured but not exposed to excessively high temperatures that could degrade the material structural properties. The thermocouples should be placed as close as practical to the area that needs to be monitored. The following steps should be taken when using thermocouples:

- Never use fewer than three thermocouples to monitor a heating cycle.
- If bonding a precured patch, place the thermocouple near the center of the patch.
- A control thermocouple may be centered over a low-temperature (200 °F or lower) co-cured patch as long as it is placed on top of a thin metallic sheet to prevent a thermocouple indentation onto the patch. This may allow for a more accurate control of the patch temperature.
- The thermocouples installed around the perimeter of the repair patch should be placed approximately 0.5 inch away from the edge of the adhesive line.

- Place flash tape below and above the thermocouple tips to protect them from resin flash and to protect the control unit from electrical shorts.
- Do not place the thermocouple under the vacuum port as the pressure may damage the lead and cause erroneous readings to occur.
- Do not place thermocouple wires adjacent to or crossing the heat blanket power cord to prevent erroneous temperature readings caused by magnetic flux lines.
- Do not place any control thermocouple beyond the heat blanket's two-inch overlap of the repair to prevent the controller from trying to compensate for the lower temperature.
- Always leave slack in the thermocouple wire under the vacuum bag to prevent the thermocouple from being pulled away from the area to be monitored as vacuum is applied.

Thermal Survey of Repair Area

In order to achieve maximum structural bonded composite repair, it is essential to cure these materials within the recommended temperature range. Failure to cure at the correct temperatures can produce weak patches and/or bonding surfaces and can result in a repair failure during service. A thermal survey should be performed prior to installing the repair to ensure proper and uniform temperatures can be achieved. The thermal survey determines the heating and insulation requirements, as well as TC locations for the repair area. The thermal survey is especially useful for determining the methods of heating (hot air modules, heat lamps, heat blanket method and monitoring requirements in cases where heat sinks (substructure for instance) exist in the repair area). It should be performed for all types of heating methods to preclude insufficient, excessive, or uneven heating of the repair area.

Temperature Variations in Repair Zone

Thermal variations in the repair area occur for many reasons. Primary among these are material type, material thickness, and underlying structure in the repair zone. For these reasons, it is important to know the structural composition of the area to be repaired. Substructure existing in the repair zone conducts heat away from the repair area, resulting in a cold spot directly above the structure. Thin skins heat quickly and can easily be overheated. Thick skin sections absorb heat slowly and take longer to reach soak temperature. The thermal survey identifies these problem areas and allows the technician to develop the heat and insulation setup required for even heating of the repair area.

Thermal Survey

During the thermal survey process, try to determine possible hot and cold areas in the repair zone. Temporarily attach a patch of the same material and thickness, several thermal couples, heating blanket, and a vacuum bag to the repair area. Heat the area and, after the temperature is stabilized, record the thermocouple temperatures. Add insulation if the temperature of the thermocouple varies more than 10 degrees from average. The areas with a stringer and rib indicate a lower temperature than the middle of the patch because they act as a heat sink. Add insulation to these areas to increase the temperature. [Figure 7-43]

Solutions to Heat Sink Problems

Additional insulation can be placed over the repair area. This insulation can also be extended beyond the repair area to minimize heat being conducted away. Breather materials and fiberglass cloths work well, either on top of the vacuum bag or within the vacuum bag or on the accessible backside of the structure. Place more insulation over cool spots and less insulation over hot spots. If access is available to the backside of the repair area, additional heat blankets could be placed there to heat the repair area more evenly.

Types of Layups

Wet Layups

During the wet layup process, a dry fabric is impregnated with a resin. Mix the resin system just before making the repair. Lay out the repair plies on a piece of fabric and impregnate the fabric with the resin. After the fabric is impregnated, cut the repair plies, stack in the correct ply orientation, and vacuum bag. Wet layup repairs are often used with fiberglass for nonstructural applications. Carbon and Kevlar® dry fabric could also be used with a wet layup resin system. Many resin systems used with wet layup cure at room temperature, are easy to accomplish, and the materials can be stored at room temperature for long period of times. The disadvantage of room temperature wet layup is that it does not restore the strength and durability of the original structure and parts that were cured at 250 °F or 350 °F during manufacturing. Some wet layup resins use an elevated temperature cure and have improved properties. In general, wet layup properties are less than properties of prepreg material.

Epoxy resins may require refrigeration until they are used. This prevents the aging of the epoxy. The label on the container states the correct storage temperature for each component. The typical storage temperature is between 40 °F and 80 °F for most epoxy resins. Some resin systems require storage below 40 °F.

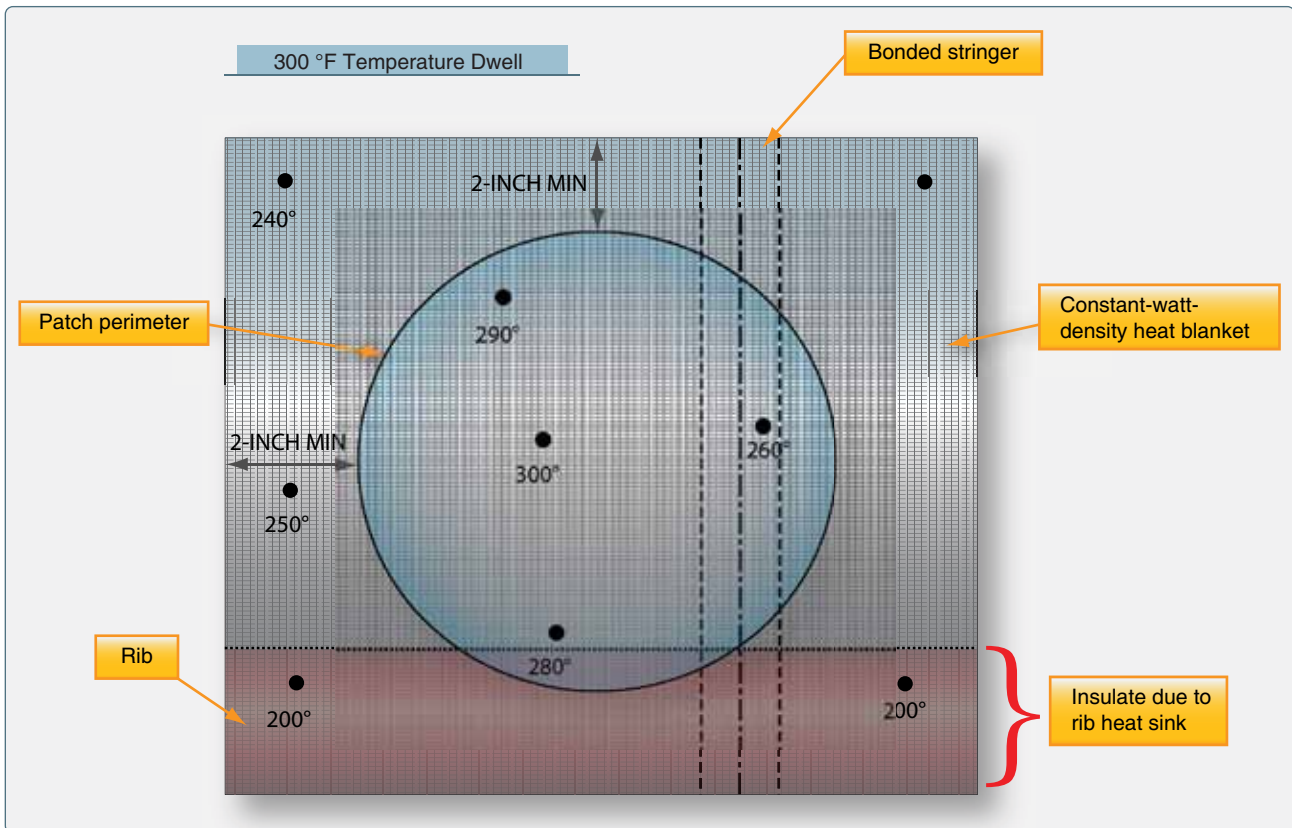

Figure 7-43. Thermal survey example.

Prepreg

Prepreg is a fabric or tape that is impregnated with a resin during the manufacturing process. The resin system is already mixed and is in the B stage cure. Store the prepreg material in a freezer below 0 °F to prevent further curing of the resin. The material is typically placed on a roll and a backing material is placed on one side of the material so that the prepreg does not stick together. The prepreg material is sticky and adheres to other plies easily during the stack-up process. You must remove the prepreg from the freezer and let the material thaw, which might take 8 hours for a full roll. Store the prepreg materials in a sealed, moisture proof bag. Do not open these bags until the material is completely thawed, to prevent contamination of the material by moisture.

After the material is thawed and removed from the backing material, cut it in repair plies, stack in the correct ply orientation, and vacuum bag. Do not forget to remove the backing material when stacking the plies. Cure prepregs at an elevated cure cycle; the most common temperatures used are 250 °F and 350 °F. Autoclaves, curing ovens, and heat bonders can be used to cure the prepreg material.

Consolidation is necessary if parts are made from several layers of prepreg, because large quantities of air can be trapped between each prepreg layer. Remove this trapped air by covering the prepreg with a perforated release film and a breather ply, and apply a vacuum bag. Apply the vacuum for 10 to 15 minutes at room temperature. Typically, attach the first consolidated ply to the tool face and repeat this process after every 3 or 5 layers depending on the prepreg thickness and component shape.

Store prepreg, film adhesive, and foaming adhesives in a freezer at a temperature below 0 °F. If these types of materials need to be shipped, place them in special containers filled with dry ice. The freezer must not be of the automatic defrost type; the auto-defrost cycle periodically warms the inside of the freezer, which can reduce the shelf life and consume the allowable out-time of the composite material. Freezers must be capable of maintaining 0 °F or below; most household freezers meet this level. Walk-in freezers can be used for large volume cold storage. If usage is small, a chest-type freezer may suffice. Refrigerators are used to store laminating and paste adhesives and should be kept near 40 °F. [Figure 7-44]

Uncured prepreg materials have time limits for storage and use. [Figure 7-45] The maximum time allowed for storing of a prepreg at low temperature is called the storage life, which is typically 6 months to a year. The material can be tested, and the storage life could be extended by the material



Figure 7-44. Walk-in freezer for storing prepreg materials.

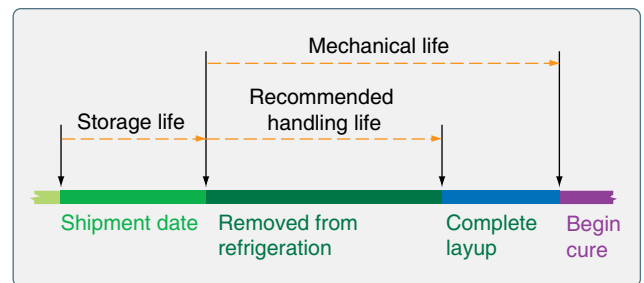

Figure 7-45. Storage life for prepreg materials.

manufacturer. The maximum time allowed for material at room temperature before the material cures is called the mechanical life. The recommended time at room temperature to complete layup and compaction is called the handling life. The handling life is shorter than the mechanical life. The mechanical life is measured from the time the material is removed from the freezer until the time the material is returned to the freezer. The operator must keep records of the time in and out of the freezer. Material that exceeds the mechanical life needs to be discarded.

Many repair facilities cut the material in smaller kits and store them in moisture-proof bags that thaw quicker when removed from the freezer. This also limits the time out of the freezer for a big roll.

All frozen prepreg materials need to be stored in moisture proof back to avoid moisture contamination. All prepreg material should be protected from dust, oil, vapors, smoke, and other contaminants. A clean room for repair layup would be best, but if a clean room is not available, the prepreg should be protected by storing them in bags or keeping them covered with plastic. Before starting the layup, cover the unprotected sides of the prepreg with parting film, and clean the area being repaired immediately before laying up the repair plies.

Prepreg material is temperature sensitive. Excessively high temperatures cause the material to begin curing, and excessively low temperatures make the material difficult to handle. For repairs on aircraft in very cold or very hot climates, the area should be protected by a tent around the repair area. Prepare the prepreg repair plies in a controlled-temperature environment and bring them to the repair area immediately before using them.

Co-curing

Co-curing is a process wherein two parts are simultaneously cured. The interface between the two parts may or may not have an adhesive layer. Co-curing often results in poor panel surface quality, which is prevented by using a secondary surfacing material co-cured in the standard cure cycle or a subsequent fill-and-fair operation. Co-cured skins may also have poorer mechanical properties, requiring the use of reduced design values.

A typical co-cure application is the simultaneous cure of a stiffener and a skin. Adhesive film is frequently placed into the interface between the stiffener and the skin to increase fatigue and peel resistance. Principal advantages derived from the co-cure process are excellent fit between bonded components and guaranteed surface cleanliness.

Secondary Bonding

Secondary bonding utilizes precured composite detail parts, and uses a layer of adhesive to bond two precured composite parts. Honeycomb sandwich assemblies commonly use a secondary bonding process to ensure optimal structural performance. Laminates co-cured over honeycomb core may have distorted plies that have dipped into the core cells. As a result, compressive stiffness and strength can be reduced as much as 10 and 20 percent, respectively.

Precured laminates undergoing secondary bonding usually have a thin nylon or fiberglass peel ply cured onto the bonding surfaces. While the peel ply sometimes hampers nondestructive inspection of the precured laminate, it has been found to be the most effective means of ensuring surface cleanliness prior to bonding. When the peel ply is stripped away, a pristine surface becomes available. Light scuff sanding removes high resin peak impressions produced by the peel ply weave which, if they fracture, create cracks in the bondline.

Composite materials can be used to structurally repair, restore, or enhance aluminum, steel, and titanium components. Bonded composite doublers have the ability to slow or stop fatigue crack growth, replace lost structural area due to corrosion grind-outs, and structurally enhance areas with

small and negative margins. This technology has often been referred to as a combination of metal bonding and conventional on-aircraft composite bonded repair. Boron prepreg tape with an epoxy resin is most often used for this application.

Co-bonding

In the co-bonding process, one of the detail parts is precured with the mating part being cured simultaneously with the adhesive. Film adhesive is often used to improve peel strength.

Layup Process (Typical Laminated Wet Layup)

Layup Techniques

Read the SRM and determine the correct repair material, number of plies required for the repair, and the ply orientation. Dry the part, remove the damage, and taper sand the edges of damaged area. Use a piece of thin plastic, and trace the size of each repair ply from the damaged area. Indicate the ply orientation of each ply on the trace sheet. Copy the repair ply information to a piece of repair material that is large enough to cut all plies. Impregnate the repair material with resin, place a piece of transparent release film over the fabric, cut out the plies, and lay up the plies in the damaged area. The plies are usually placed using the smallest ply first taper layup sequence, but an alternative method is to use the largest ply first layup sequence. In this sequence, the first layer of reinforcing fabric completely covers the work area, followed by successively smaller layers, and then is finished with an extra outer layer or two extending over the patch and onto the sound laminate for some distance. Both methods are illustrated in *Figures 7-46 and 7-47*.

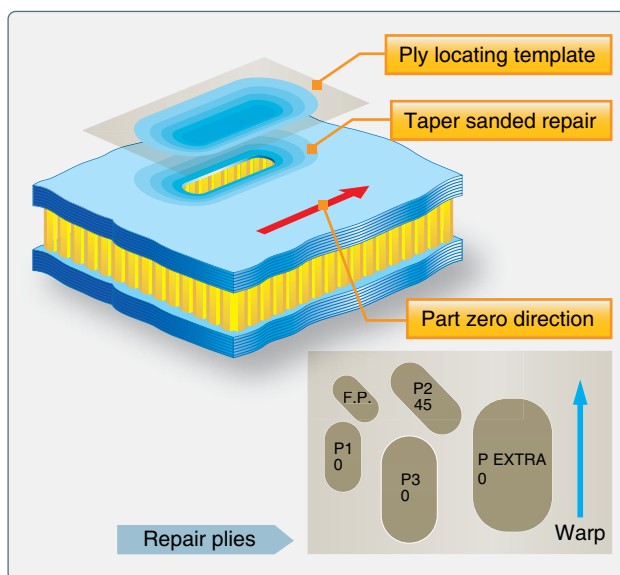

Figure 7-46. Repair layup process.

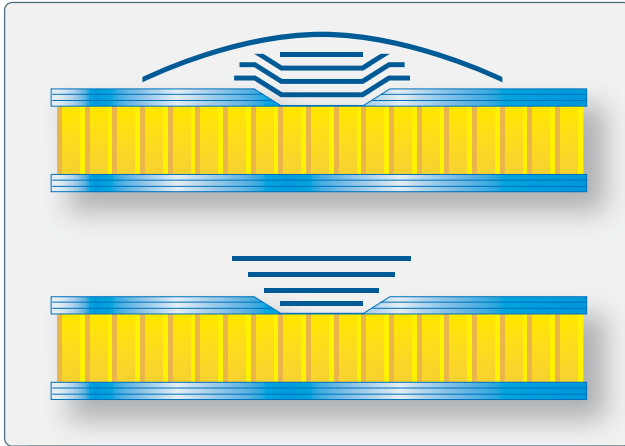

Figure 7-47. *Different lay-up techniques.*

Bleedout Technique

The traditional bleedout using a vacuum bag technique places a perforated release film and a breather/bleeder ply on top of the repair. The holes in the release film allow air to breath and resin to bleed off over the entire repair area. The amount of resin bled off depends on the size and number of holes in the perforated release film, the thickness of the bleeder/ breather cloth, the resin viscosity and temperature, and the vacuum pressure.

Controlled bleed allows a limited amount of resin to bleed out in a bleeder ply. Place a piece of perforated release film on top of the prepreg material, a bleeder ply on top of the perforated release film, and a solid release film on top of the bleeder. Use a breather and a vacuum bag to compact the repair. The breather allows the air to escape. The bleeder can only absorb a limited amount of resin, and the amount of resin that is bled can be controlled by using multiple bleeder plies. Too many bleeder plies can result in a resin-starved repair. Always consult the maintenance manual or manufacturer tech sheets for correct bagging and bleeding techniques.

No Bleedout

Prepreg systems with 32 to 35 percent resin content are typically no-bleed systems. These prepregs contain exactly the amount of resin needed in the cured laminate; therefore, resin bleedoff is not desired. Bleedout of these prepregs results in a resin-starved repair or part. Many high-strength prepregs in use today are no-bleed systems. No bleeder is used, and the resin is trapped/sealed so that none bleeds away. Consult the maintenance manual to determine if bleeder plies are required for the repair. A sheet of solid release film (no holes) is placed on top of the prepreg and taped off at the edges with flash tape. Small openings are created at the edges of the tape so that air can escape. A breather and vacuum bag are installed to compact the prepreg plies. The air can escape on the edge of the repair but no resin can bleed out. [Figure 7-48]

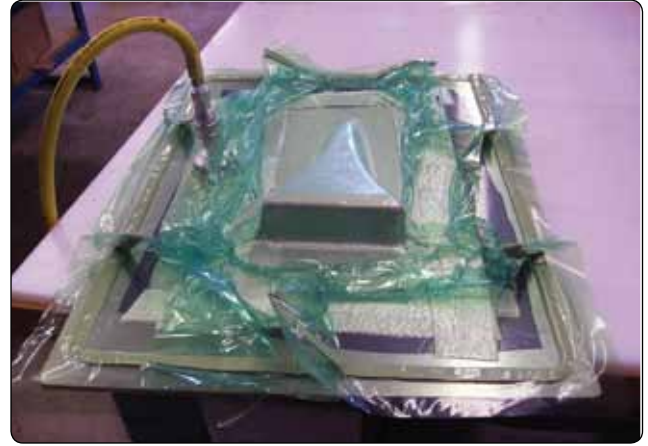

Figure 7-48. *Vacuum bagging of contoured part.*

Horizontal (or edge) bleedout is used for small room temperature wet layup repairs. A 2-inch strip of breather cloth is placed around the repair or part (edge breather). There is no need for a release film because there is no bleeder/breather cloth on top of the repair. The part is impregnated with resin, and the vacuum bag is placed over the repair. A vacuum is applied and a squeegee is used to remove air and excess resin to the edge breather.

Ply Orientation Warp Clock

In order to minimize any residual thermal stresses caused during cure of the resin, it is always good practice to design a symmetrical, or balanced, laminate. Examples of balance laminates are presented in Figure 7-49. The first example uses unidirectional tape, and examples 2 and 3 are typical quasi-isotropic laminates fabricated from woven cloth.

Example	Lamina	Written as
1	$\pm 45^\circ, -45^\circ, 0^\circ, 0^\circ, -45^\circ, +45^\circ$	(+45, -45, 0) S
2	$\pm 45^\circ, 0^\circ/90^\circ, \pm 45^\circ, 0^\circ/90^\circ, 0^\circ/90^\circ, \pm 45^\circ, 0^\circ/90^\circ, \pm 45^\circ$	($\pm 45, 0/90$)2S
3	$\pm 45^\circ, \pm 45^\circ, 0^\circ/90^\circ, 0^\circ/90^\circ, \pm 45^\circ, \pm 45^\circ$	([± 45] 2, 0/90) S

Figure 7-49. *Examples of balance laminates.*

Figure 7-50 presents examples of the effects caused by nonsymmetrical laminates. These effects are most pronounced in laminates that are cured at high temperature in an autoclave or oven due to the thermal stresses developed in the laminate as the laminate cools down from the cure temperature to room temperature. Laminates cured at room temperature using typical wet layup do not exhibit the same degree of distortion due to the much smaller thermal stresses.

Type	Example	Comments
Symmetrical, balanced	(+45, -45, 0, 0, -45, +45)	Flat, constant midplane stress
Nonsymmetrical, balanced	(90, +45, 0, 90, -45, 0)	Induces curvature
Symmetrical, nonbalanced	(-45, 0, 0, -45)	Induces twist
Nonsymmetrical, nonbalanced	(90, -45, 0, 90, -45, 0)	Induces twist and curvature

Figure 7-50. Examples of the effects caused by nonsymmetrical laminates.

The strength and stiffness of a composite buildup depends on the ply orientation. The practical range of strength and stiffness of carbon epoxy extends from values as low as those provided by fiberglass to as high as those provided by titanium. This range of values is determined by the orientation of the plies to the applied load. Because the strength design requirement is a function of the applied load direction, ply orientation and ply sequence must be correct. It is critical during a repair operation to replace each damaged ply with a ply of the same material and orientation or an approved substitute.

Warp is the longitudinal fibers of a fabric. The warp is the high-strength direction due to the straightness of the fibers. A warp clock is used to describe direction of fibers on a diagram, spec sheet, or manufacturer's sheets. If the warp clock is not available on the fabric, the orientation is defaulted to zero as the fabric comes off the roll. Therefore, 90° to zero is across the width of the fabric. 90° to zero is also called the fill direction.

Mixing Resins

Epoxy resins, like all multipart materials, must be thoroughly mixed. Some resin systems have a dye added to aid in seeing how well the material is mixed. Since many resin systems do not have a dye, the resin must be mixed slowly and fully for three minutes. Air enters into the mixture if the resin is mixed too fast. If the resin system is not fully mixed, the resin may not cure properly. Make sure to scrape the edges and bottom of the mixing cup to ensure that all resin is mixed correctly.

Do not mix large quantities of quick curing resin. These types of resins produce heat after they are mixed. Smoke can burn or poison you when the resin overheats. Mix only the amount of material that is required. Mix more than one batch if more material is needed than the maximum batch size.

Saturation Techniques

For wet layup repair, impregnate the fabric with resin. It is important to put the right amount of resin on the fabric. Too much or too little resin affects the strength of the repair. Air that is put into the resin or not removed from the fabric also reduces the repair strength.

Fabric Impregnation With a Brush or Squeegee

The traditional way of impregnating the fabric is by using a brush or squeegee. The technician puts a mold release compound or a release film on a caul plate so that the plies will not adhere to the caul plate. Place a sheet of fabric on the caul plate and apply resin in the middle of the sheet. Use a brush or squeegee to thoroughly wet the fabric. More plies of fabric and resin are added and the process is repeated until all plies are impregnated. A vacuum bag will be used to consolidate the plies and to bleed off excess resin and volatiles. Most wet layup processes have a room temperature cure but extra heat, up to 150 °F, are used to speed up the curing process. [Figure 7-51]

Fabric Impregnation Using a Vacuum Bag

The vacuum-assisted impregnation method is used to impregnate repair fabric with a two-part resin while enclosed inside a vacuum bag. This method is preferred for tight-knit weaves and when near optimum resin-to-fiber ratio is required. Compared to squeegee impregnation, this process reduces the level of entrapped air within the fabric and offers a more controlled and contained configuration for completing the impregnation process.

Vacuum-assisted impregnation consists of the following steps:

1. Place vacuum bag sealing tape on the table surface around the area that is used to impregnate the material. The area should be at least 4 inches larger than the material to be impregnated.
2. Place an edge breather cloth next to the vacuum bag sealing tape. The edge breather should be 1–2 inches wide.
3. Place a piece of solid parting film on the table. The sheet should be 2-inches larger than the material to be impregnated.
4. Weigh the fabric to find the amount of resin mix that is necessary to impregnate the material.
5. Lay the fabric on the parting film.
6. Put a piece of breather material between the fabric and the edge breather to provide an air path.



Figure 7-51. Fabric impregnation with a brush or squeegee: A) wet layup materials; B) fabric placement; C) fabric impregnation; D) squeegee used to thoroughly wet the fabric.

7. Pour the resin onto the fabric. The resin should be a continuous pool in the center area of the fabric.
8. Put vacuum probes on the edge breather.
9. Place a second piece of solid parting film over the fabric. This film should be the same size or larger than the first piece.
10. Place and seal the vacuum bag, and apply vacuum to the bag.
11. Allow 2 minutes for the air to be removed from the fabric.
12. Sweep the resin into the fabric with a squeegee. Slowly sweep the resin from the center to the edge of the fabric. The resin should be uniformly distributed over all of the fabric.
13. Remove the fabric and cut the repair plies.

Vacuum Bagging Techniques

Vacuum bag molding is a process in which the layup is cured under pressure generated by drawing a vacuum in the space

between the layup and a flexible sheet placed over it and sealed at the edges. In the vacuum bag molding process, the plies are generally placed in the mold by hand layup using prepreg or wet layup. High-flow resins are preferred for vacuum bag molding.

Single Side Vacuum Bagging

This is the preferred method if the repair part is large enough for a vacuum bag on one side of the repair. The vacuum bag is taped in place with tacky tape and a vacuum port is placed through the bag to create the vacuum.

Envelope Bagging

Envelope bagging is a process in which the part to be repaired is completely enclosed in a vacuum bag or the bag is wrapped around the end of the component to obtain an adequate seal. It is frequently used for removable aircraft parts, such as flight controls, access panels, etc., and when a part's geometry and/or the repair location makes it very difficult to properly vacuum bag and seal the area in a vacuum. In some cases, a part may be too small to allow installation of a single-side

bag vacuum. Other times, the repair is located on the end of a large component that must have a vacuum bag wrapped around the ends and sealed all the way around. [Figure 7-52]



Figure 7-52. *Envelope bagging of repair.*

Alternate Pressure Application

Shrink Tape

Another method of pressure application for oven cures is the use of shrink wrapping or shrink tape. This method is commonly used with parts that have been filament wound, because some of the same rules for application apply. The tape is wrapped around the completed layup, usually with only a layer of release material between the tape and the layup. Heat is applied to the tape, usually using a heat gun to make the tape shrink, a process that can apply a tremendous amount of pressure to the layup. After shrinking, the part is placed in the oven for cure. High quality parts can be made inexpensively using shrink tape.

C-Clamps

Parts can also be pressed together with clamps. This technique is used for solid laminate edges of honeycomb panels. Clamps (e.g., C-clamps and spring clamps) are used for pressing together the edges of components and/or repair details. Always use clamps with pressure distribution pads because damage to the part may occur if the clamping force is too high. Spring clamps can be used in applications where resin squeeze-out during cure would require C-clamps to be retightened periodically.

Shotbags and Weights

Shotbags and weights can be used also to provide pressure, but their use is limited due to the low level of pressure imposed.

Curing of Composite Materials

A cure cycle is the time/temperature/pressure cycle used to cure a thermosetting resin system or prepreg. The curing of a repair is as important as the curing of the original part material. Unlike metal repairs in which the materials are premanufactured, composite repairs require the technician to manufacture the material. This includes all storage, processing, and quality control functions. An aircraft repair's cure cycle starts with material storage. Materials that are stored incorrectly can begin to cure before they are used for a repair. All time and temperature requirements must be met and documented. Consult the aircraft structural repair manual to determine the correct cure cycle for the part that needs to be repaired.

Room Temperature Curing

Room temperature curing is the most advantageous in terms of energy savings and portability. Room temperature cure wet layup repairs do not restore either the strength or the durability of the original 250 °F or 350 °F cure components and are often used for wet layup fiberglass repairs for noncritical components. Room temperature cure repairs can be accelerated by the application of heat. Maximum properties are achieved at 150 °F. A vacuum bag can be used to consolidate the plies and to provide a path for air and volatiles to escape.

Elevated Temperature Curing

All prepreg materials are cured with an elevated temperature cure cycle. Some wet layup repairs use an elevated cure cycle as well to increase repair strength and to speed up the curing process. The curing oven and heat bonder uses a vacuum bag to consolidate the plies and to provide a path for air and volatiles to escape. The autoclave uses vacuum and positive pressure to consolidate the plies and to provide a path for air and volatiles to escape. Most heating devices use a programmable computer control to run the cure cycles. The operator can select from a menu of available cure cycles or write his or her own program. Thermocouples are placed near the repair, and they provide temperature feedback for the heating device. Typical curing temperature for composite materials is 250 °F or 350 °F. The temperature of large parts that are cured in an oven or autoclave might be different from that of an oven or autoclave during the cure cycle, because they act like a heat sink. The part temperature is most important for a correct cure, so thermocouples are placed on the part to monitor and control part temperature. The oven or autoclave air temperature probe that measures oven or autoclave temperature is not always a reliable device to determine part curing temperature. The oven temperature and the part temperature can be substantially different if the part or tool acts as a heat sink.

The elevated cure cycle consists of at least three segments:

- Ramp up: The heating device ramps up at a set temperature typically between 3 °F to 5 °F per minute.
- Hold or soak: The heating device maintains the temperature for a predetermined period.
- Cool down: The heating device cools down at a set temperature. Cool down temperatures are typically below 5 °F per minute. When the heating device is below 125 °F, the part can be removed. When an autoclave is used for curing parts, make sure that the pressure in the autoclave is relieved before the door is opened. [Figure 7-53]

The curing process is accomplished by the application of heat and pressure to the laminate. The resin begins to soften and flow as the temperature is increased. At lower temperatures,

very little reaction occurs. Any volatile contaminants, such as air and/or water, are drawn out of the laminate with vacuum during this time. The laminate is compacted by applying pressure, usually vacuum (atmospheric pressure); autoclaves apply additional pressure, typically 50–100 psi. As the temperature approaches the final cure temperature, the rate of reaction greatly increases, and the resin begins to gel and harden. The hold at the final cure lets the resin finish curing and attain the desired structural properties.

Composite Honeycomb Sandwich Repairs

A large proportion of current aerospace composite components are light sandwich structures that are susceptible to damage and are easily damaged. Because sandwich structure is a bonded construction and the face sheets are thin, damage to sandwich structure is usually repaired by

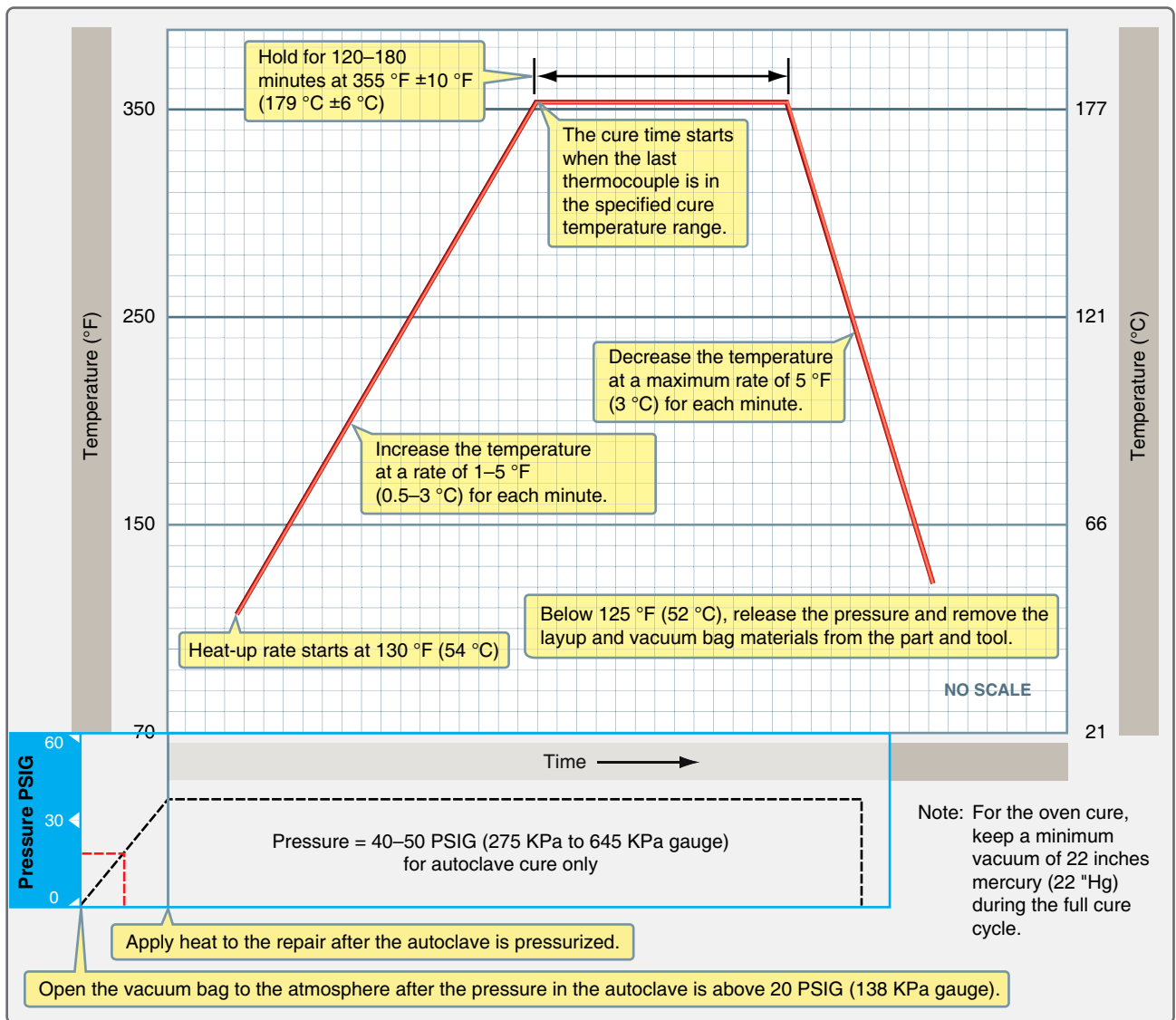

Figure 7-53. Autoclave cure.

bonding. Repairs to sandwich honeycomb structure use similar techniques for the most common types of face sheet materials, such as fiberglass, carbon, and Kevlar®. Kevlar® is often repaired with fiberglass. [Figure 7-54]

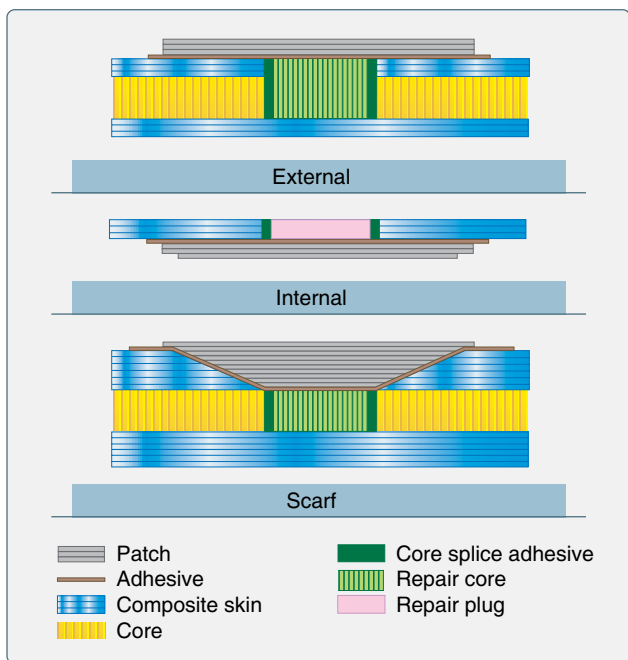

Figure 7-54. Typical repairs for honeycomb sandwich structure.

Damage Classification

A temporary repair meets the strength requirements, but is limited by time or flight cycles. At the end of the repair's life, the repair must be removed and replaced. An interim repair restores the required strength to the component. However, this repair does not restore the required durability to the component. Therefore, it has a different inspection interval and/or method. A permanent repair is a repair that restores the required strength and durability to the component. The repair has the same inspection method and interval as the original component.

Sandwich Structures

Minor Core Damage (Filler and Potting Repairs)

A potted repair can be used to repair damage to a sandwich honeycomb structure that is smaller than 0.5 inches. The honeycomb material could be left in place or could be removed and is filled up with a potting compound to restore some strength. Potted repairs do not restore the full strength of the part.

Potting compounds are most often epoxy resins filled with hollow glass, phenolic or plastic microballoons, cotton, floc, or other materials. The potting compound can also be used as filler for cosmetic repairs to edges and skin panels. Potting compounds are also used in sandwich honeycomb panels as hard points for bolts and screws. The potting compound is heavier than the original core and this could affect flight control balance. The weight of the repair must be calculated and compared with flight control weight and balance limits set out in the SRM.

Damage Requiring Core Replacement and Repair to One or Both Faceplates

Note: the following steps are not a substitution for the aircraft specific Structural Repair Manual (SRM). Do not assume that the repair methods used by one manufacturer are applicable to another manufacturer.

Step 1: Inspect the Damage

Thin laminates can be visually inspected and tap tested to map out the damage. [Figure 7-55] Thicker laminates need more in-depth NDI methods, such as ultrasonic inspection. Check in the vicinity of the damage for entry of water, oil, fuel, dirt, or other foreign matter. Water can be detected with X-ray, back light, or a moisture detector.

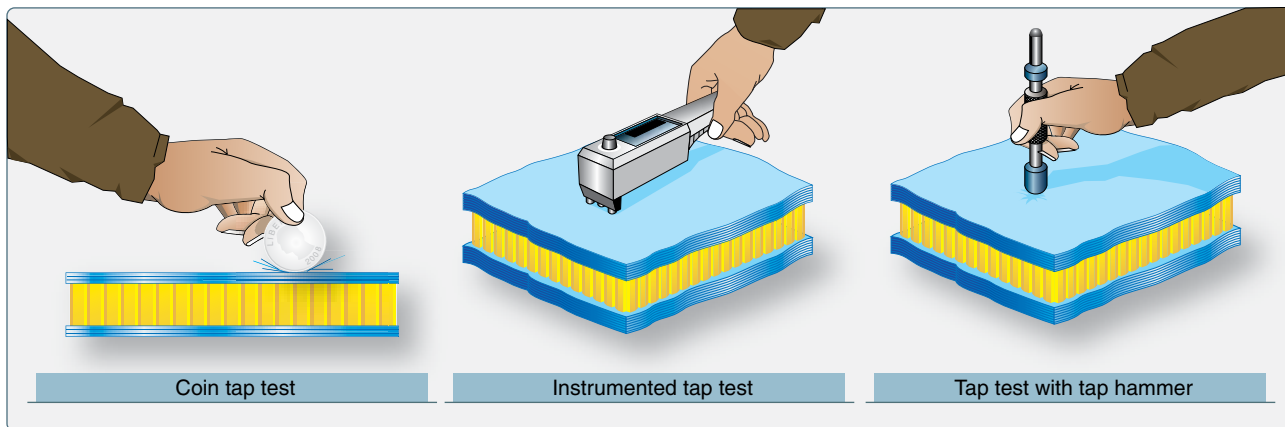

Figure 7-55. Tap testing techniques.

Step 2: Remove Water From Damaged Area

Water needs to be removed from the core before the part is repaired. [Figure 7-56] If the water is not removed, it boils during the elevated temperature cure cycle and the face sheets blow off the core, resulting in more damage. Water in the

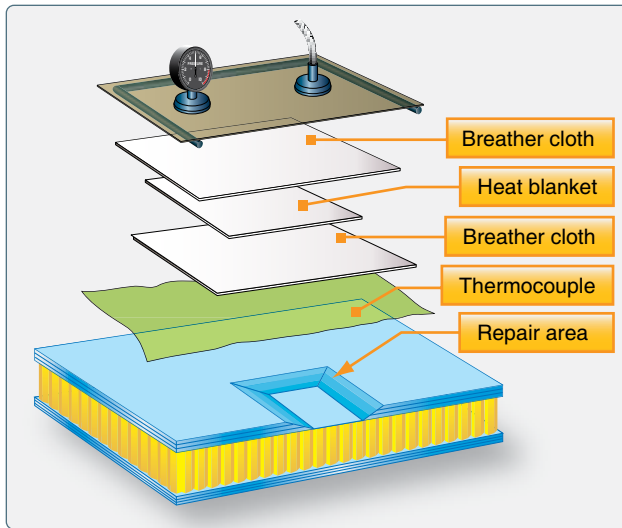

Figure 7-56. Vacuum bag method for drying parts.

honeycomb core could also freeze at the low temperatures that exist at high altitudes, which could result in disbonding of the face sheets.

Step 3: Remove the Damage

Trim out the damage to the face sheet to a smooth shape with rounded corners, or a circular or oval shape. Do not damage the undamaged plies, core, or surrounding material. If the core is damaged as well, remove the core by trimming to the same outline as the skin. [Figure 7-57]

Step 4: Prepare the Damaged Area

Use a flexible disk sander or a rotating pad sander to taper sand a uniform taper around the cleaned up damage. Some manufacturers give a taper ratio, such as 1:40, and others prescribe a taper distance like a 1-inch overlap for each existing ply of the face sheet. Remove the exterior finish, including conductive coating for an area that is at least 1 inch larger than the border of the taper. Remove all sanding dust with dry compressed air and a vacuum cleaner. Use a clean cloth moistened with approved solvent to clean the damaged area. [Figure 7-58]

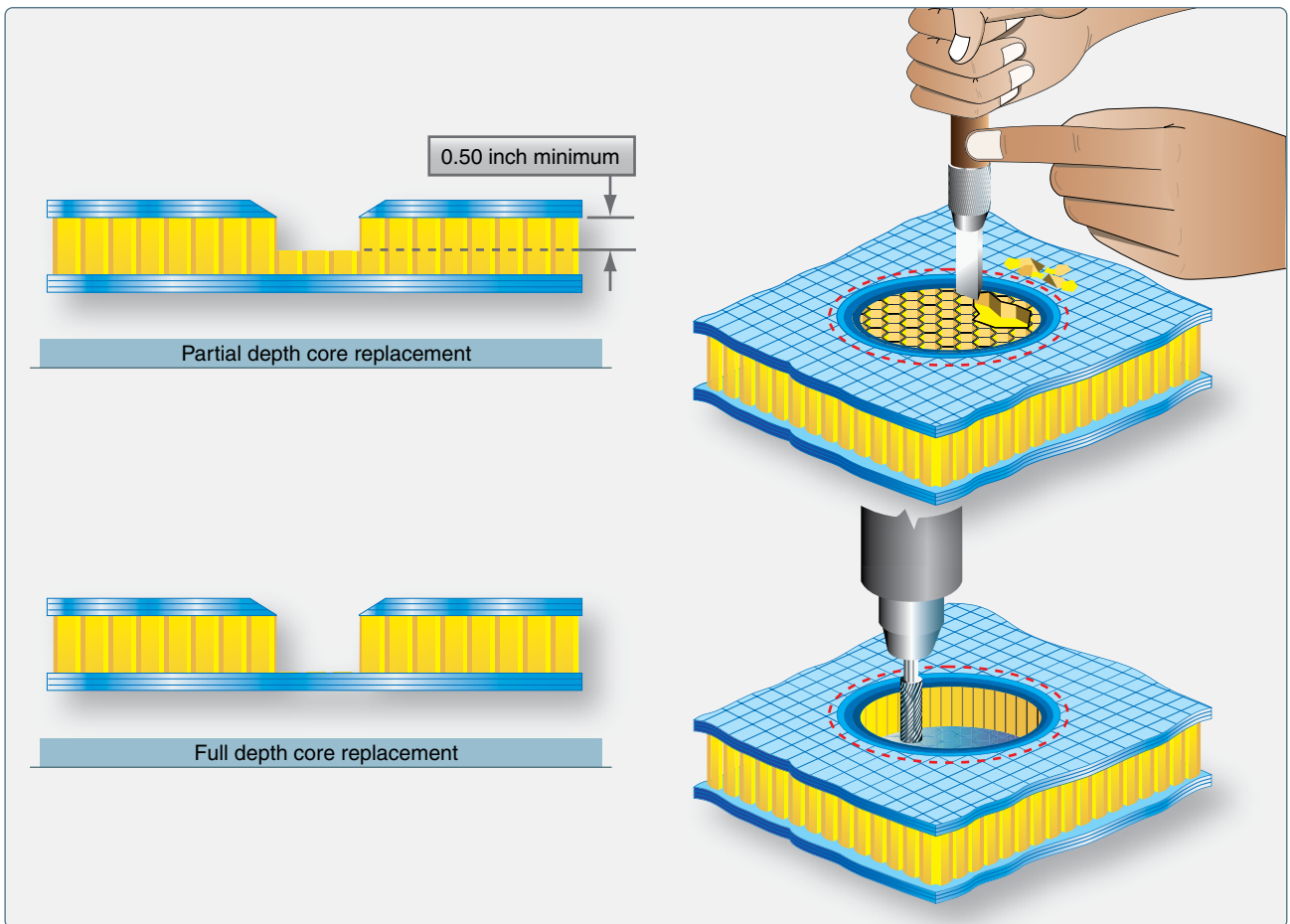

Figure 7-57. Core damage removal.



Figure 7-58. Taper sanding of repair area.

Step 5: Installation of Honeycomb Core (Wet Layup)

Use a knife to cut the replacement core. The core plug must be of the same type, class, and grade of the original core. The direction of the core cells should line up with the honey comb of the surrounding material. The plug must be trimmed to the right length and be solvent washed with an approved cleaner.

For a wet layup repair, cut two plies of woven fabric that fit on the inside surface of the undamaged skin. Impregnate the fabric plies with a resin and place in the hole. Use potting compound around the core and place it in the hole. For a prepreg repair, cut a piece of film adhesive that fits the hole and use a foaming adhesive around the plug. The plug should touch the sides of the hole. Line up the cells of the plug with the original material. Vacuum bag the repair area and use an oven, autoclave, or heat blanket to cure the core replacement. The wet layup repair can be cured at a room temperature up to 150 °F. The prepreg repair must be cured at 250 °F or 350 °F. Usually, the core replacement is cured with a separate curing cycle and not co-cured with the patch. The plug must be sanded flush with the surrounding area after the cure. [Figure 7-59]

Step 6: Prepare and Install the Repair Plies

Consult the repair manual for the correct repair material and the number of plies required for the repair. Typically, one more ply than the original number of plies is installed. Cut the plies to the correct size and ply orientation. The repair plies must be installed with the same orientation as that of the original plies being repaired. Impregnate the plies with resin for the wet layup repair, or remove the backing material from the prepreg material. The plies are usually placed using the smallest ply first taper layup sequence. [Figure 7-60]

Step 7: Vacuum Bag the Repair

Once the ply materials are in place, vacuum bagging is used to remove air and to pressurize the repair for curing. Refer to Figure 7-61 for bagging instructions.

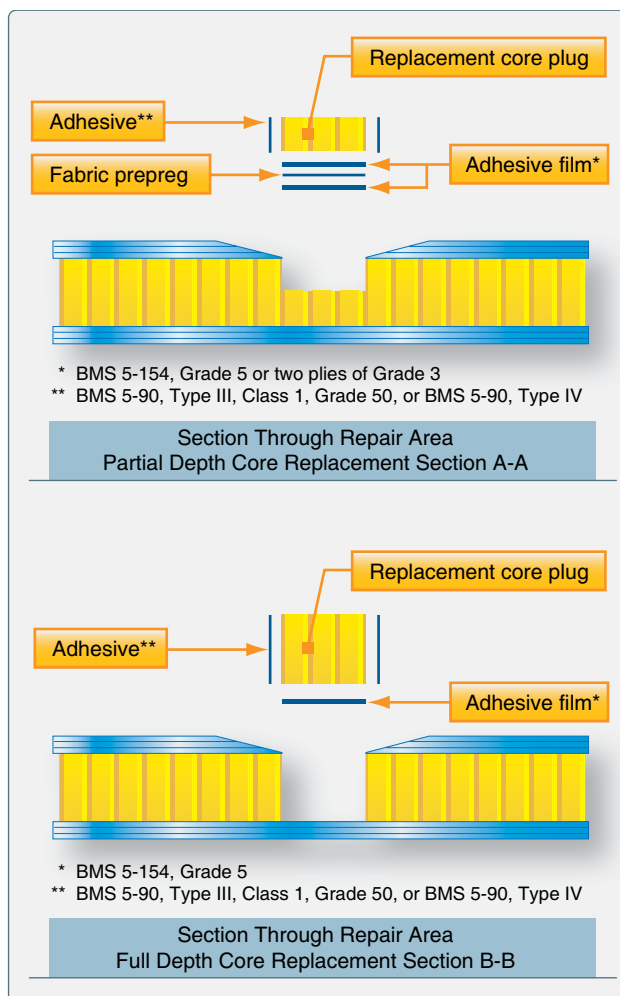

Figure 7-59. Core replacement.

Step 8: Curing the Repair

The repair is cured at the required cure cycle. Wet layup repairs can be cured at room temperature. An elevated temperature up to 150 °F can be used to speed up the cure. The prepreg repair needs to be cured at an elevated cure cycle. [Figure 7-62] Parts that can be removed from the aircraft could be cured in a hot room, oven, or autoclave. A heating blanket is used for on-aircraft repairs.

Remove the bagging materials after curing and inspect the repair. The repair should be free from pits, blisters, resin-rich and resin-starved areas. Lightly sand the repair patch to produce a smooth finish without damaging the fibers. Apply top finish and conductive coating (lighting protection).

Step 9: Post Repair Inspection

Use visual, tap, and/or ultrasonic inspection to inspect the repair. Remove the repair patch if defects are found. [Figure 7-63]

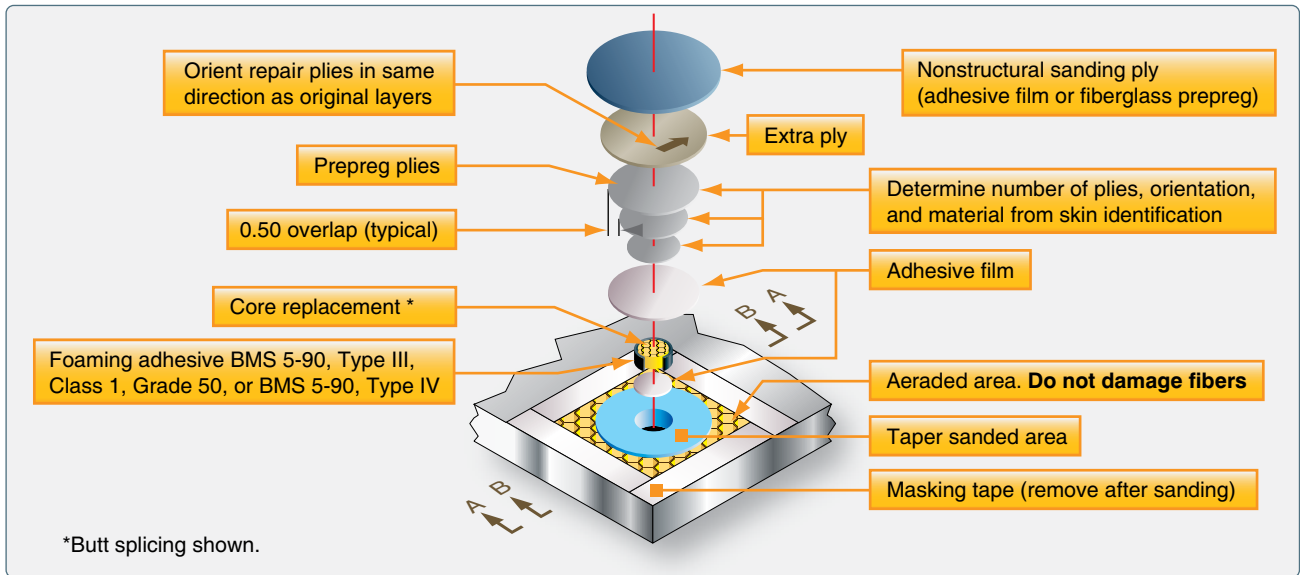

Figure 7-60. Repair ply installation.

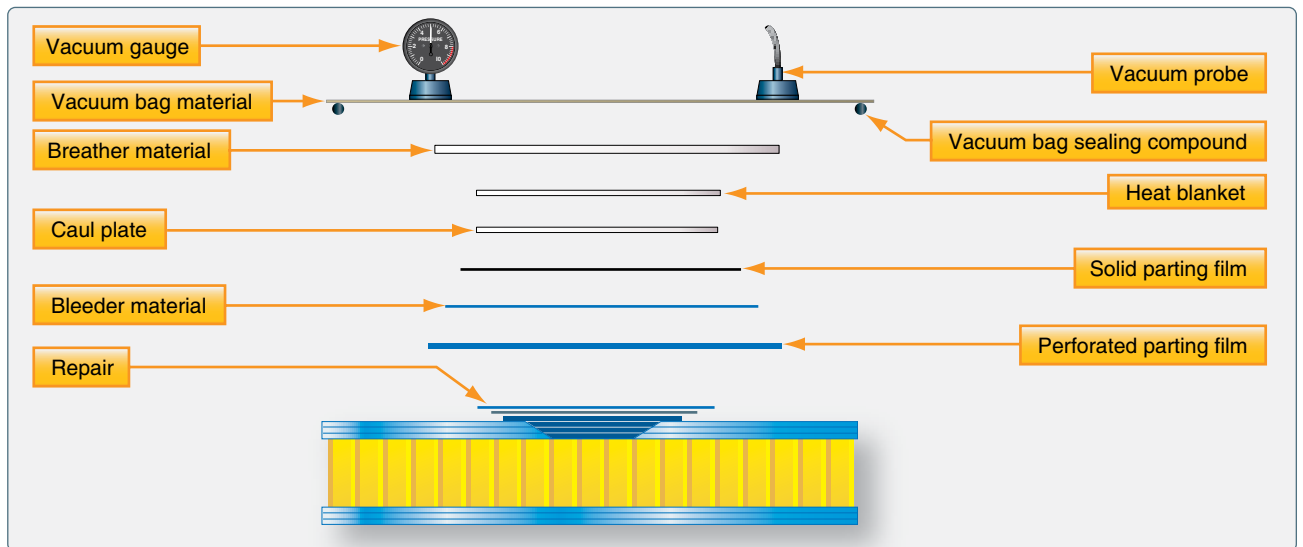

Figure 7-61. Vacuum processing.

Perform a balance check if a repair to a flight control surface was made, and ensure that the repaired flight control is within limits of the SRM. Failure to do so could result in flight control flutter, and safety of flight could be affected.

Solid Laminates

Bonded Flush Patch Repairs

New generation aircraft have fuselage and wing structures made from solid laminates that are externally stiffened with co-cured or co-bonded stringers. These solid laminates have many more plies than the face sheets of honeycomb sandwich structures. The flush repair techniques for solid laminate structures are similar for fiberglass, Kevlar®, and graphite with minor differences.

A flush repair can be stepped or, more commonly, scarfed (tapered). The scarf angles are usually small to ease the load into the joint and to prevent the adhesive from escaping. This translates into thickness-to-length ratios of 1:10 to 1:70. Because inspection of bonded repairs is difficult, bonded repairs, as contrasted with bolted repairs, require a higher commitment to quality control, better trained personnel, and cleanliness.

The scarf joint is more efficient from the viewpoint of load transfer as it reduces load eccentricity by closely aligning the neutral axis of the parent and the patch. However, this configuration has many drawbacks in making the repair. First, to maintain a small taper angle, a large quantity of

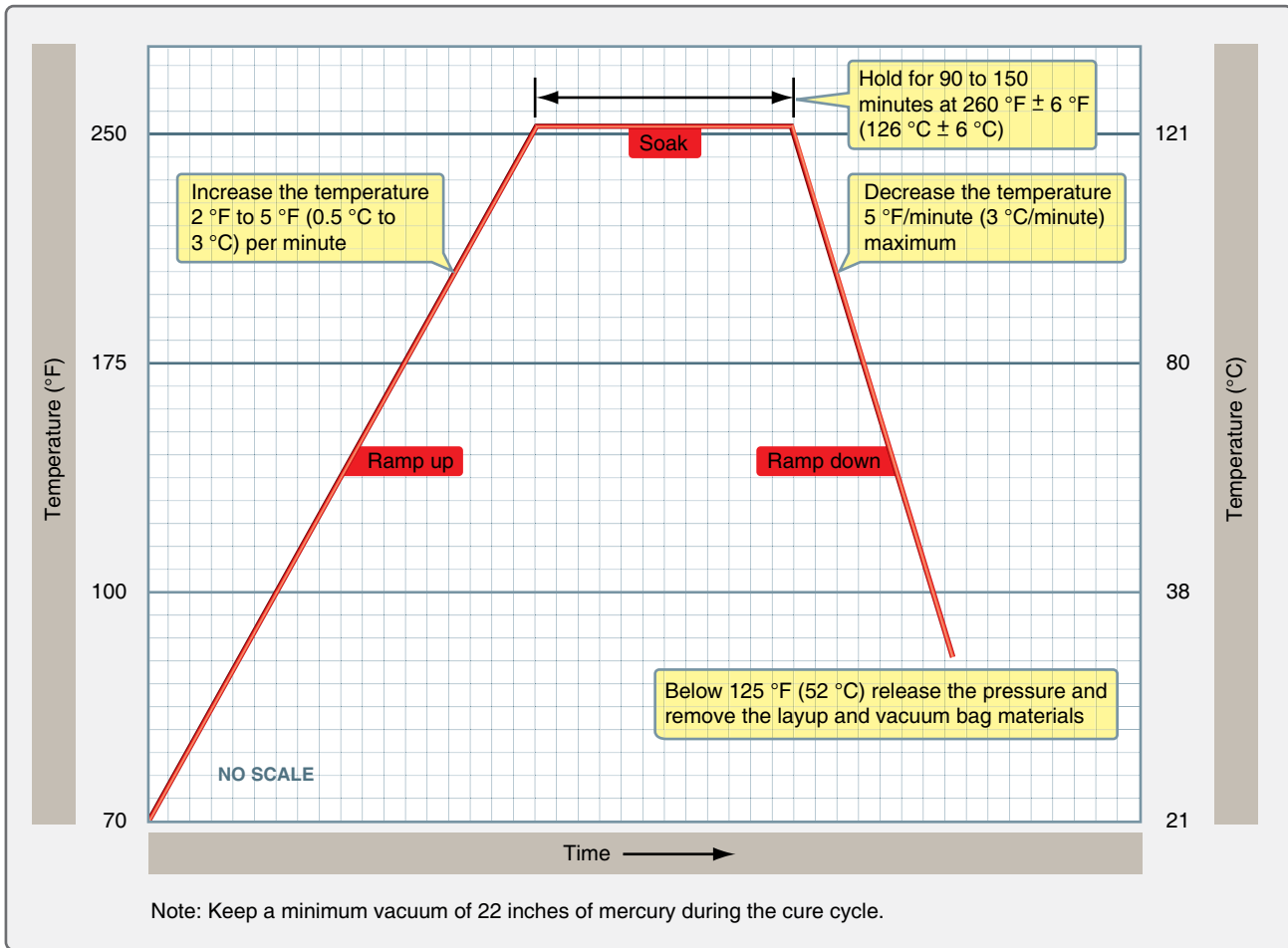

Figure 7-62. Curing the repair.

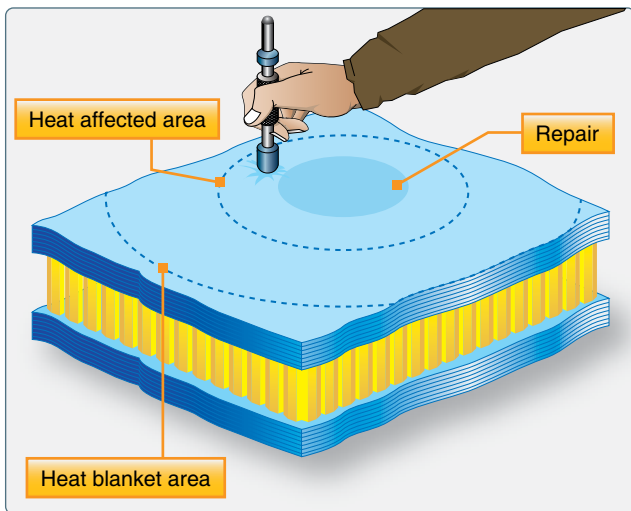

Figure 7-63. Postrepair inspection.

sound material must be removed. Second, the replacement plies must be very accurately laid up and placed in the repair joint. Third, curing of replacement plies can result in significantly reduced strength if not cured in the autoclave. Fourth, the adhesive can run to the bottom of the joint, creating a nonuniform bond line. This can be alleviated by approximating the scarf with a series of small steps. For these reasons, unless the part is lightly loaded, this type of repair is usually performed at a repair facility where the part can be inserted into the autoclave, which can result in part strength as strong as the original part.

There are several different repair methods for solid laminates. The patch can be precured and then secondarily bonded to the parent material. This procedure most closely approximates the bolted repair. [Figure 7-64] The patch can be made from prepreg and then co-cured at the same time as the adhesive. The patch can also be made using a wet layup repair. The curing cycle can also vary in length of time, cure temperature, and cure pressure, increasing the number of possible repair combinations.

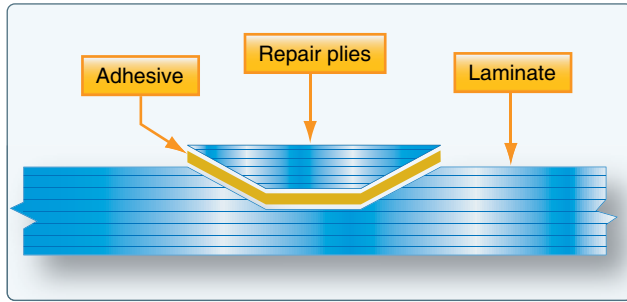

Figure 7-64. A precured patch can be secondarily bound to the parent material.

Scarf repairs of composite laminates are performed in the sequence of steps described below.

Step 1: Inspection and Mapping of Damage

The size and depth of damage to be repaired must be accurately surveyed using appropriate nondestructive evaluation (NDE) techniques. A variety of NDE techniques can be used to inspect for damage in composite structures. The simplest technique is visual inspection, in which whitening due to delamination and/or resin cracking can be used to indicate the damage area in semitransparent composites, such as glass-polyester and glass-vinyl ester laminates.

Visual inspection is not an accurate technique because not all damage is detectable to the eye, particularly damage hidden by paint, damage located deep below the surface, and damage in nontransparent composites, such as carbon and aramid laminates. A popular technique is tap testing, in which a lightweight object, such as a coin or hammer, is used to locate damage. The main benefits of tap testing are that it is simple and it can be used to rapidly inspect large areas. Tap testing can usually be used to detect delamination damage close to the surface, but becomes increasingly less reliable the deeper the delamination is located below the surface. Tap testing is not useful for detecting other types of damage, such as resin cracks and broken fibers.

More advanced NDE techniques for inspecting composites are impedance testing, x-ray radiography, thermography, and ultrasonics. Of these techniques, ultrasonics is arguably the most accurate and practical and is often used for surveying damage. Ultrasonics can be used to detect small delaminations located deep below the surface, unlike visual inspection and tap testing.

Step 2: Removal of Damaged Material

Once the scope of the damaged area to be repaired has been determined, the damaged laminate must be removed. The edges of the sound laminate are then tapered back to a shallow angle. The taper slope ratio, also known as the scarf angle, should be less than 12 to 1 ($< 5^\circ$) to minimize

the shear strains along the bond line after the repair patch is applied. The shallow angle also compensates for some errors in workmanship and other shop variables that might diminish patch adhesion. [Figure 7-65]

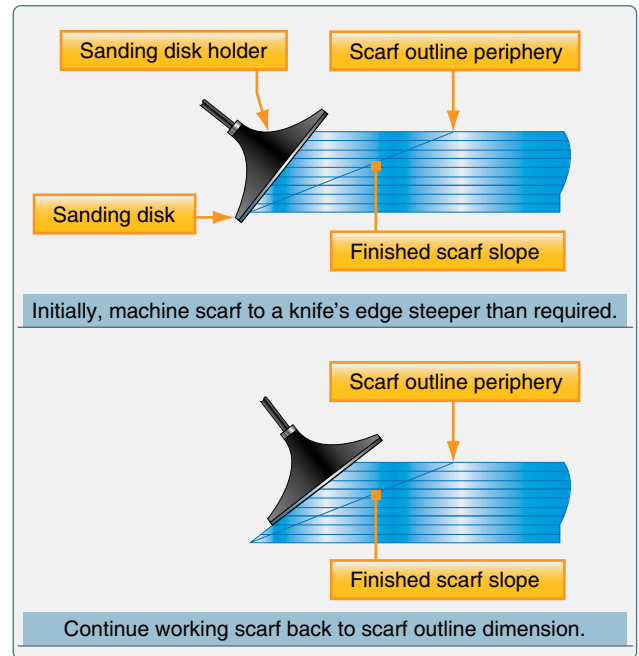

Figure 7-65. Scarf patch of solid laminate.

Step 3: Surface Preparation

The laminate close to the scarf zone should be lightly abraded with sandpaper, followed by the removal of dust and contaminants. It is recommended that, if the scarf zone has been exposed to the environment for any considerable period of time, it should be cleaned with a solvent to remove contamination.

Step 4: Molding

A rigid backing plate having the original profile of the composite structure is needed to ensure the repair has the same geometry as the surrounding structure.

Step 5: Laminating

Laminated repairs are usually done using the smallest ply-first taper sequence. While this repair is acceptable, it produces relatively weak, resin-rich areas at each ply edge at the repair interface. The largest ply first laminate sequence, where the first layer of reinforcing fabric completely covers the work area, produces a stronger interface joint. Follow the manufacturer's SRM instructions.

Selection of the reinforcing material is critical to ensuring the repair has acceptable mechanical performance. The reinforcing fabric or tape should be identical to the reinforcement material used in the original composite. Also,

the fiber orientation of the reinforcing layers within the repair laminate should match those of the original part laminate, so that the mechanical properties of the repair are as close to original as possible.

Step 6: Finishing

After the patch has cured, a conducting mesh and finish coat should be applied if needed.

Trailing Edge and Transition Area Patch Repairs

Trailing edges of control panels are highly vulnerable to damage. The aft 4 inches are especially subject to ground collision and handling, as well as to lightning strike. Repairs in this region can be difficult because both the skins and the trailing edge reinforcement may be involved. The repairs to a honeycomb core on a damaged edge or panel are similar to the repair of a sandwich honeycomb structure discussed in the Damage Requiring Core Replacement and Repair to One or Both Faceplate Repair sections. Investigate the damage, remove damaged plies and core, dry the part, install new core, layup the repair plies, curing and post inspection. A typical trail edge repair is shown in Figure 7-66.

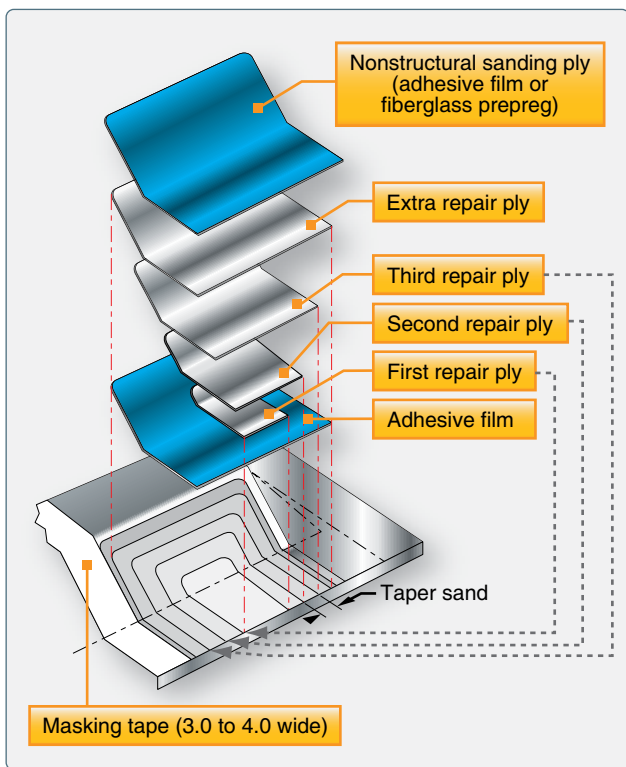

Figure 7-66. Trailing edge repair.

Resin Injection Repairs

Resin injection repairs are used on lightly loaded structures for small damages to a solid laminate due to delamination. Two holes are drilled on the outside of the delamination area and a low-viscosity resin is injected in one hole until it flows

out the other hole. Resin injection repairs are sometimes used on sandwich honeycomb structure to repair a facesheet disbond. Disadvantages of the resin injection method are that the fibers are cut as a result of drilling holes, it is difficult to remove moisture from the damaged area, and it is difficult to achieve complete infusion of resin. [Figure 7-67]

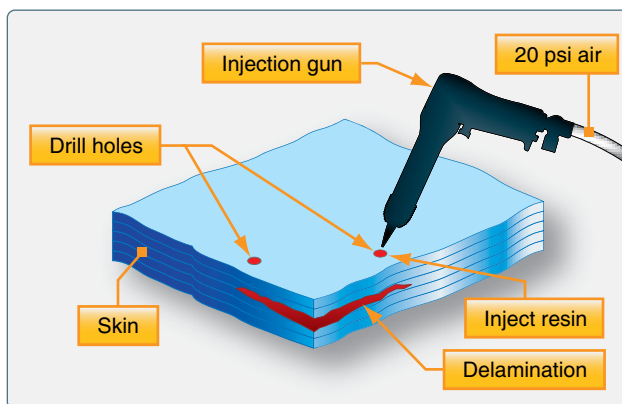

Figure 7-67. Resin injection repair.

Composite Patch Bonded to Aluminum Structure

Composite materials can be used to structurally repair, restore, or enhance aluminum, steel, and titanium components. Bonded composite doublers have the ability to slow or stop fatigue crack growth, replace lost structural area due to corrosion grindouts, and structurally enhance areas with small and negative margins.

Boron epoxy, GLARE®, and graphite epoxy materials have been used as composite patches to restore damaged metallic wing skins, fuselage sections, floor beams, and bulkheads. As a crack growth inhibitor, the stiff bonded composite materials constrain the cracked area, reduce the gross stress in the metal, and provide an alternate load path around the crack. As a structural enhancement or blendout filler, the high modulus fiber composites offer negligible aerodynamic resistance and tailorable properties.

Surface preparation is very important to achieve the adhesive strength. Grit blast silane and phosphoric acid anodizing are used to prepare aluminum skin. Film adhesives using a 250 °F (121 °C) cure are used routinely to bond the doublers to the metallic structure. Critical areas of the installation process include a good thermal cure control, having and maintaining water free bond surfaces, and chemically and physically prepared bond surfaces.

Secondarily bonded precured doublers and in-situ cured doublers have been used on a variety of structural geometries ranging from fuselage frames to door cutouts to blade stiffeners. Vacuum bags are used to apply the bonding and curing pressure between the doubler and metallic surface.

Fiberglass Molded Mat Repairs

Fiberglass molded mats consists of short fibers, and the strength is much less than other composite products that use continuous fibers. Fiberglass molded mats are not used for structural repair applications, but could be used for non-structural applications. The fiberglass molded mat is typically used in combination with fiberglass fabric. The molded mats are impregnated with resin just like a wet layup for fiberglass fabric. The advantage of the molded mat is the lower cost and the ease of use.

Radome Repairs

Aircraft radomes, being an electronic window for the radar, are often made of nonconducting honeycomb sandwich structure with only three or four plies of fiberglass. The skins are so thin so that they do not block the radar signals. The thin structure, combined with the location in front of the aircraft, makes the radome vulnerable to hail damage, bird strikes, and lightning strikes. Low-impact damage could lead to disbonds and delamination. Often, water is found in the radome structure due to impact damage or erosion. The moisture collects in the core material and begins a freeze-thaw cycle each time the airplane is flown. This eventually breaks down the honeycomb material causing a soft spot on the radome itself. Damage to a radome needs to be repaired quickly to avoid further damage and radar signal obstructions. Trapped water or moisture can produce a shadow on the radar image and severely degrade the performance of the radar. To detect water ingress in radomes, the available NDE techniques include x-ray radiography, infrared thermography, and a radome moisture meter that measures the RF power loss caused by the presence of water. The repairs to radomes are similar to repairs to other honeycomb structures, but the technician needs to realize that repairs could affect the radar performance. A special tool is necessary to repair severely damaged radomes. [Figure 7-68]

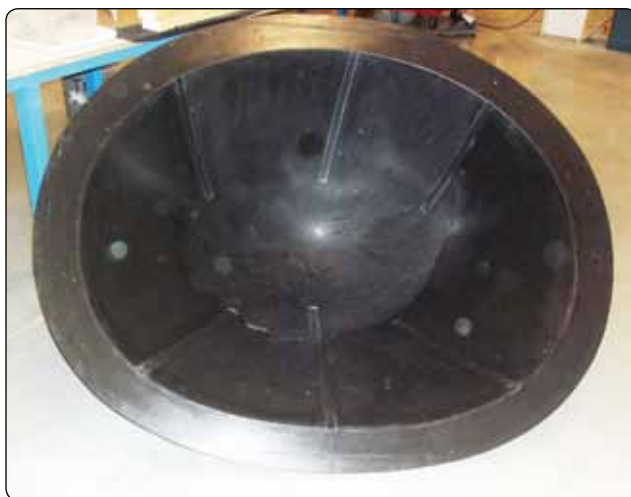

Figure 7-68. Radome repair tool.

Transmissivity testing after radome repair ensures that the radar signal is transmitted properly through the radome. Radomes have lightning protection strips bonded to the outside of the radome to dissipate the energy of a lightning strike. It is important that these lightning protection strips are in good condition to avoid damage to the radome structure. Typical failures of lightning protection strips that are found during inspection are high resistance caused by shorts in the strips or attaching hardware and disbonding of the strips from the radome surface. [Figures 7-69]

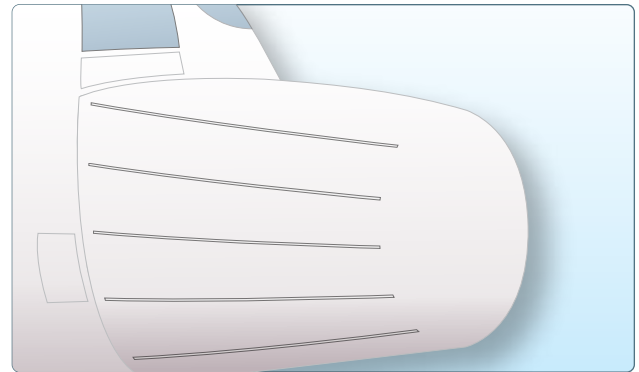

Figure 7-69. Lightning protection strips on a radome.

External Bonded Patch Repairs

Repairs to damaged composite structures can be made with an external patch. The external patch repair could be made with prepreg, a wet layup, or a precured patch. External patches are usually stepped to reduce the stress concentration at the edge of the patch. The disadvantages of the external patch are the eccentricity of the loading that causes peel stresses and the protrusion of the patch in the air stream. The advantage of the external patch is that it is easier to accomplish than a flush scarf-type repair.

External Bonded Repair With Prepreg Plies

The repair methods for carbon, fiberglass, and Kevlar® are similar. Fiberglass is sometimes used to repair Kevlar® material. The main steps in repairing damage with an external patch are investigating and mapping the damage, removal of the damage, layup of the repair plies, vacuum bagging, curing, and finish coating.

Step 1: Investigating and Mapping the Damage

Use the tap test or ultrasonic test to map out the damage.

Step 2: Damage Removal

Trim out the damage to a smooth round or oval shape. Use scotch or sand paper to rough up the parent surface at least 1 inch larger than the patch size. Clean the surface with an approved solvent and cheese cloth.

Step 3: Layup of the Repair Plies

Use the SRM to determine the number, size, and orientation of the repair plies. The repair ply material and orientation must be the same as the orientation of the parent structure. The repair can be stepped to reduce peel stresses at the edges.

Step 4: Vacuum Bagging

A film adhesive is placed over the damaged area and the repair layup is placed on top of the repair. The vacuum bagging materials are placed on top of the repair (see Prepreg Layup and Controlled Bleed Out) and a vacuum is applied.

Step 5: Curing the Repair

The prepreg patch can be cured with a heater blanket that is placed inside the vacuum bag, oven, or autoclave when the part can be removed from the aircraft. Most prepregs and film adhesives cure at either 250 °F or 350 °F. Consult the SRM for the correct cure cycle.

Step 6: Applying Top Coat

Remove the vacuum bag from the repair after the cure and inspect the repair, remove the patch if the repair is not satisfactory. Lightly sand the repair and apply a protective topcoating.

External Repair Using Wet Layup and Double Vacuum Debulk Method (DVD)

Generally, the properties of a wet layup repair are not as good as a repair with prepreg material; but by using a DVD method, the properties of the wet layup process can be improved. The DVD process is a technique to remove entrapped air that causes porosity in wet layup laminates. The DVD process is often used to make patches for solid laminate structures for complex contoured surfaces. The wet layup patch is prepared in a DVD tool and then secondary bonded to the aircraft structure. [Figure 7-70] The laminating process is similar to a standard wet layup process. The difference is how the patch is cured.

Double Vacuum Debulk Principle

The double vacuum bag process is used to fabricate wet layup or prepreg repair laminates. Place the impregnated fabric within the debulking assembly, shown in Figure 7-70. To begin the debulking process, evacuate the air within the inner flexible vacuum bag. Then, seal the rigid outer box onto the inner vacuum bag, and evacuate the volume of air between the rigid outer box and inner vacuum bag. Since the outer box is rigid, the second evacuation prevents atmospheric pressure from pressing down on the inner vacuum bag over the patch. This subsequently prevents air bubbles from being pinched off within the laminate and facilitates air removal by the inner vacuum. Next, heat the laminate to a predetermined debulking temperature in order to reduce the resin viscosity and further improve the removal of air and volatiles from the laminate. Apply the heat through a heat blanket that is controlled with thermocouples placed directly on the heat blanket. Once the debulking cycle is complete, compact the laminate to consolidate the plies by venting the vacuum source attached to the outer rigid box, allowing atmospheric pressure to reenter the box and provide positive pressure against the inner vacuum bag. Upon completion of the compaction cycle, remove the laminate from the assembly and prepare for cure.

DVD tools can be purchased commercially but can also be fabricated locally from wood two by fours and sheets of plywood, as illustrated in Figure 7-70.

Patch Installation on the Aircraft

After the patch comes out of the DVD tool, it is still possible to form it to the contour of the aircraft, but the time is typically limited to 10 minutes. Place a film adhesive, or paste adhesive, on the aircraft skin and place the patch on the aircraft. Use a vacuum bag and heater blanket to cure the adhesive. [Figures 7-71 and 7-72]

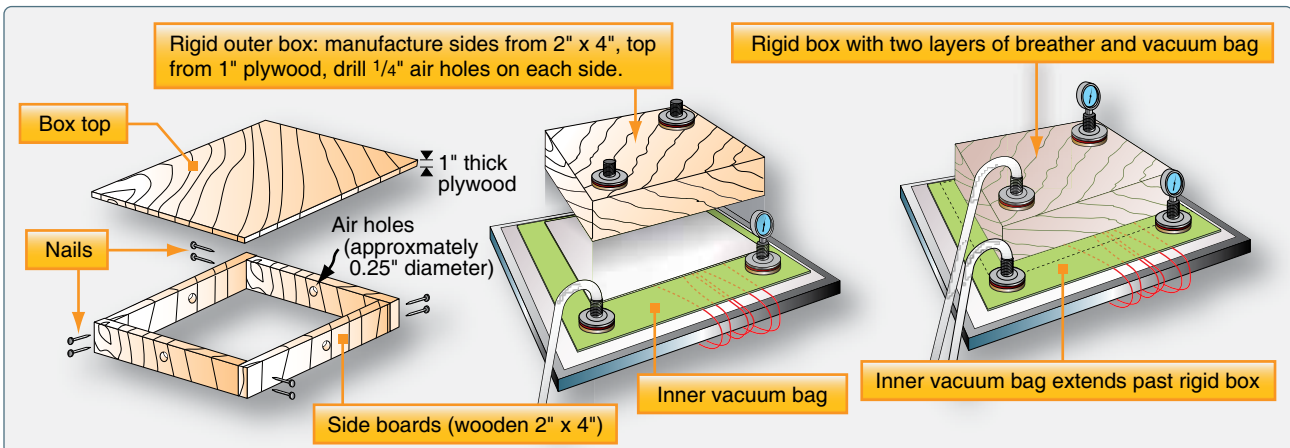

Figure 7-70. DVD tool made from wood two by fours and plywood.

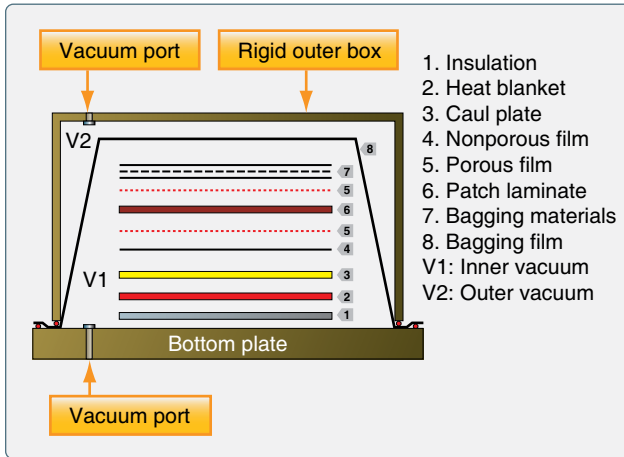

Figure 7-71. Double vacuum debulk schematic.

External Repair Using Precured Laminate Patches

Precured patches are not very flexible and cannot be used on highly curved or compound curved surfaces. The repair steps are similar as in External Bonded Repair With Prepreg Plies, except step 3 and 4 that follow.

Step 3: A Precured Patch

Consult the SRM for correct size, ply thickness, and orientation. You can laminate and cure the precured patch in the repair shop and secondary bond to the parent structure, or obtain standard precured patches. [Figure 7-73]



Figure 7-73. Precured patches.

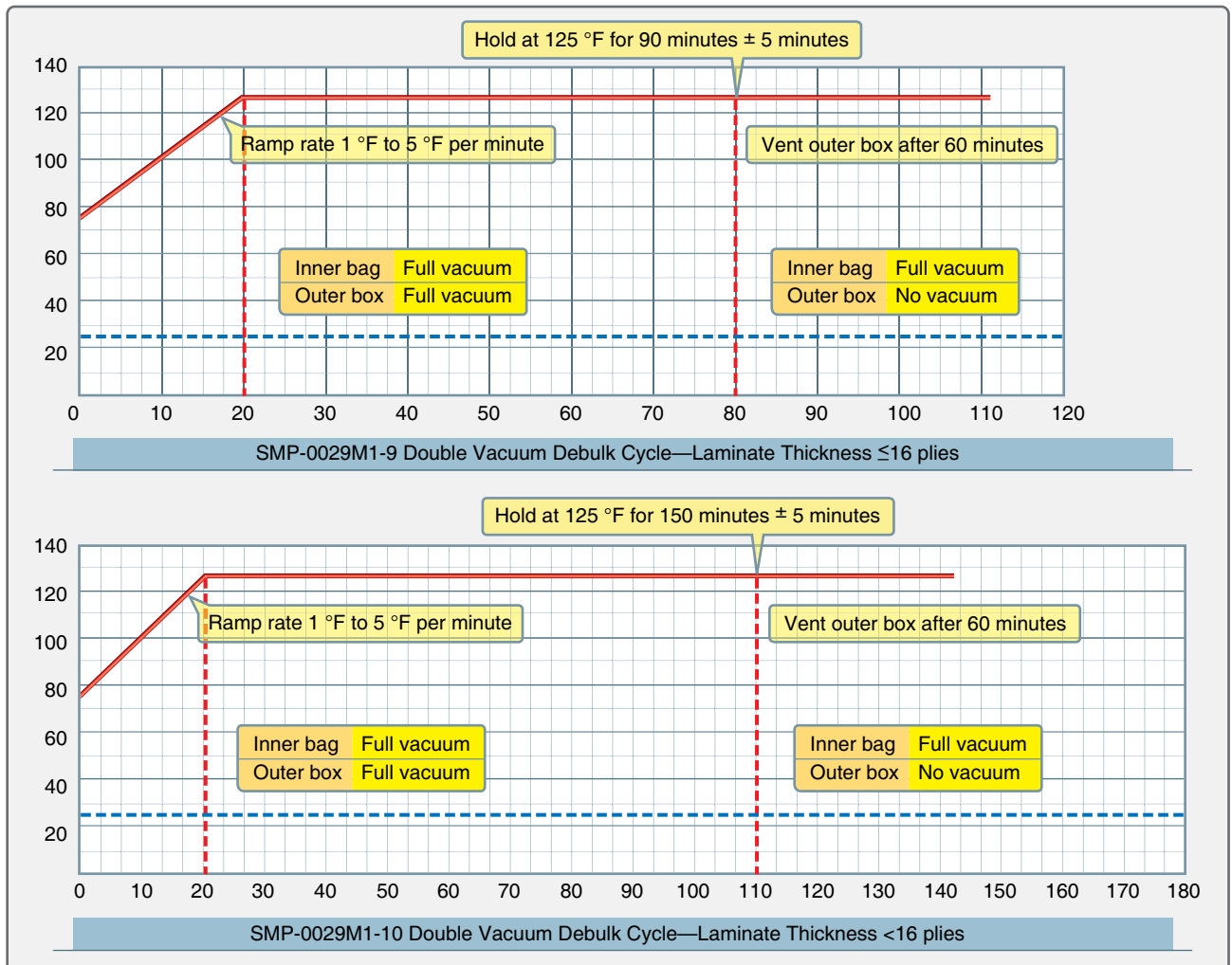

Figure 7-72. DVD cure cycle.

Step 4: For a Precured Patch

Apply film adhesive or paste adhesive to the damaged area and place the precured patch on top. Vacuum bag the repair and cure at the correct temperature for the film adhesive or paste adhesive. Most film adhesive cure at either 250 °F or 350 °F. Some paste adhesives cure at room temperature although an elevated temperature could be used to speed the curing process.

Bonded versus Bolted Repairs

Bonded repair concepts have found applicability in both types of manufacturing assembly methods. They have the advantage of not introducing stress concentrations by drilling fastener holes for patch installation and can be stronger than original part material. The disadvantage of bonded repairs is that most repair materials require special storage, handling, and curing procedures.

Bolted repairs are quicker and easier to fabricate than bonded repairs. They are normally used on composite skins thicker than 0.125-inch to ensure sufficient fastener bearing area is available for load transfer. They are prohibited in honeycomb sandwich assemblies due to the potential for moisture intrusion from the fastener holes and the resulting core degradation. Bolted repairs are heavier than comparable bonded repairs, limiting their use on weight-sensitive flight control surfaces.

Honeycomb sandwich parts often have thin face sheets and are most effectively repaired by using a bonded scarf type repair. A bonded external step patch can be used as an alternative. Bolted repairs are not effective for thin laminates because of the low bearing stress of the composite laminate. Thicker solid laminates used on larger aircraft can be up to an inch thick in highly loaded areas and these types of laminates cannot be effectively repaired using a bonded scarf type repair. [Figure 7-74]

Bolted Repairs

Aircraft designed in the 1970s used composite sandwich honeycomb structure for lightly loaded secondary structure, but new large aircraft use thick solid laminates for primary structure instead of sandwich honeycomb. These thick solid laminate structures are quite different from the traditional sandwich honeycomb structures used for flight controls, landing gear doors, flaps, and spoilers of today’s aircraft. They present a challenge to repair and are difficult to repair with a bonded repair method. Bolted repair methods have been developed to repair thicker solid laminates.

Bolted repairs are not desirable for honeycomb sandwich structure due to the limited bearing strength of the thin face sheets and weakened honeycomb structure from drilling

Bonded versus bolted repair	Bolted	Bonded
Lightly loaded structures – laminate thickness less than 0.1"		X
Highly loaded structures – laminate thickness between 0.125" – 0.5"	X	X
Highly loaded structures – laminate thickness larger than 0.5"	X	
High peeling stresses	X	
Honeycomb structure		X
Dry surfaces	X	X
Wet and/or contaminated surfaces	X	
Disassembly required	X	
Restore unnotched strength		X

Figure 7-74. Bolted versus bonded repair.

holes. The advantage of a bolted repair is that you need to select only patch material and fasteners, and the repair method is similar to a sheet metal repair. There is no need for curing the repair and storing the prepreg repair material and film adhesives in a freezer. Patches may be made from aluminum, titanium, steel, or precured composite material. Composite patches are often made from carbon fiber with an epoxy resin or fiberglass with an epoxy resin.

You can repair a carbon fiber structure with an aluminum patch, but you must place a layer of fiberglass cloth between the carbon part and the aluminum patch to prevent galvanic corrosion. Titanium and precured composite patches are preferred for repair of highly loaded components. Precured carbon/epoxy patches have the same strength and stiffness as the parent material as they are usually cured similarly.

Titanium or stainless steel fasteners are used for bolted repairs of a carbon fiber structure. Aluminum fasteners corrode if used with carbon fiber. Rivets cannot be used because the installation of rivets using a rivet gun introduce damage to the hole and surrounding structure and rivets expand during installation, which is undesirable for composite structures because it could cause delamination of the composite material.

Repair Procedures

Step 1: Inspection of the Damage

The tap test is not effective to detect delamination in thick laminates unless the damage is close to the surface. An

ultrasonic inspection is necessary to determine the damage area. Consult the SRM to find an applicable NDI procedure.

Step 2: Removal of the Damage

The damaged area needs to be trimmed to a round or rectangular hole with large smooth radii to prevent stress concentrations. Remove the damage with a sander, router, or similar tool.

Step 3: Patch Preparation

Determine the size of the patch based on repair information found in the SRM. Cut, form, and shape the patch before attaching the patch to the damaged structure. It is easier to make the patch a little bigger than calculated and trim to size after drilling all fastener holes. In some cases, the repair patches are stocked preshaped and predrilled. If cutting is to be performed, standard shop procedures should be used that are suitable for the patch material. Titanium is hard to work and requires a large powerful slip roller to curve the material. Metal patches require filing to prevent crack initiation around the cut edges. When drilling pilot holes in the composite, the holes for repair fasteners must be a minimum of four diameters from existing fasteners and have a minimum edge distance of three fastener diameters. This is different from the standard practice for aluminum of allowing a two diameter distance. Specific pilot hole sizes and drill types to be used should follow specific SRM instructions. [Figure 7-75]

Step 4: Hole Pattern Lay Out

To locate the patch on the damaged area, draw two perpendicular centerlines on the parent structure and on the patch material that define the principal load or geometric directions. Then, lay out hole pattern on the patch and drill

pilot holes in the patch material. Align the two perpendicular centerlines of the patch with the lines on the parent structure and transfer the pilot holes to the parent material. Use clecos to keep the patch in place. Mark the edges of the patch so that it can be returned to the same location easily.

Step 5: Drilling and Reaming Holes in Patch and Parent Structure

Composite skins should be backed up to prevent splitting. Enlarge the pilot holes in the patch and parent materials with a drill $\frac{1}{64}$ undersize and then ream all holes to the correct size. A tolerance of $+0.0025/-0.000$ -inch is usually recommended for aircraft parts. For composites, this means interference fasteners are not used.

Step 6: Fastener Installation

Once fastener holes are drilled full size and reamed, permanent fasteners are installed. Before installation, measure the fastener grip length for each fastener using a grip length gauge. As different fasteners are required for different repairs, consult the SRM for permissible fastener type and installation procedure. However, install all fasteners wet with sealant and with proper torque for screws and bolts.

Step 7: Sealing of Fasteners and Patch

Sealants are applied to bolted repairs for prevention of water/moisture intrusion, chemical damage, galvanic corrosion, and fuel leaks. They also provide contour smoothness. The sealant must be applied to a clean surface. Masking tape is usually placed around the periphery of the patch, parallel with the patch edges and leaving a small gap between the edge of the patch and the masking tape. Sealing compound is applied into this gap.

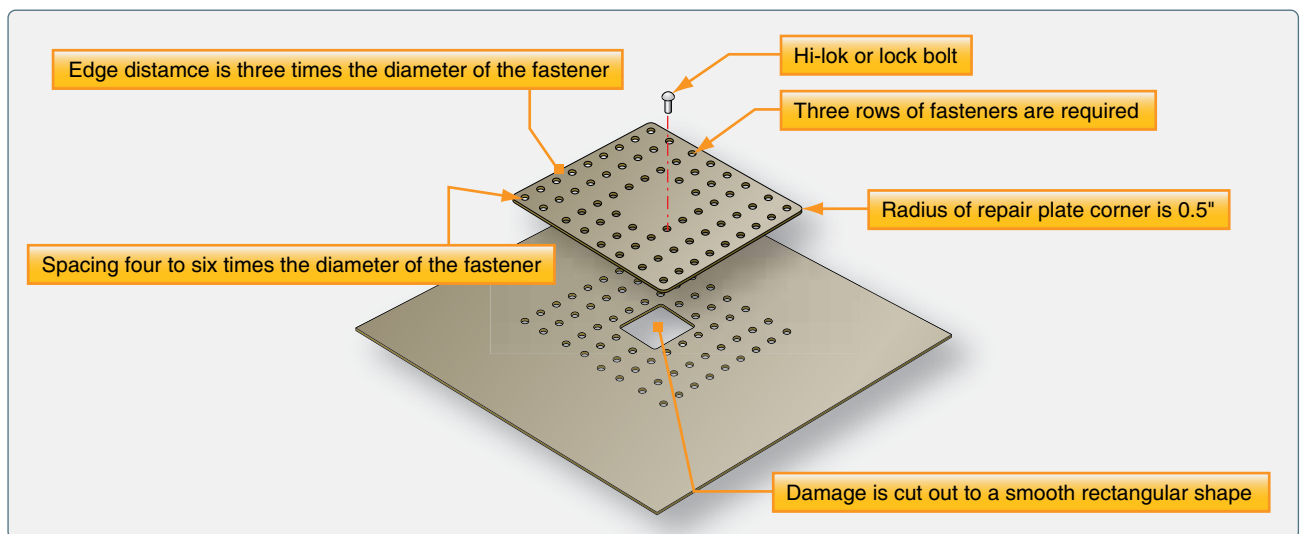

Figure 7-75. Repair layout for bolted repair of composite structure.

Step 8: Application of Finish Coat and Lightning Protection Mesh

The repair needs to be sanded, primed, and painted with an approved paint system. A lightning protection mesh needs to be applied if composite patches are used in an area that is prone to lightning strikes.

Fasteners Used with Composite Laminates

Many companies make specialty fasteners for composite structures and several types of fasteners are commonly used: threaded fasteners, lock bolts, blind bolts, blind rivets, and specialty fasteners for soft structures, such as honeycomb panels. The main differences between fasteners for metal and composite structures are the materials and the footprint diameter of nuts and collars.

Corrosion Precautions

Neither fiberglass nor Kevlar® fiber reinforced composites cause corrosion problems when used with most fastener materials. Composites reinforced with carbon fibers, however, are quite cathodic when used with materials, such as aluminum or cadmium, the latter of which is a common plating used on fasteners for corrosion protection.

Fastener Materials

Titanium alloy Ti-6Al-4V is the most common alloy for fasteners used with carbon fiber reinforced composite structures. Austenitic stainless steels, superalloys (e.g., A286), multiphase alloys (e.g., MP35N or MP159), and nickel alloys (e.g., alloy 718) also appear to be very compatible with carbon fiber composites.

Fastener System for Sandwich Honeycomb Structures (SPS Technologies Comp Tite)

The adjustable sustain preload (ASP) fastening system provides a simplified method of fastening composite, soft core, metallic or other materials, which are sensitive to fastener clamp-up or installation force conditions. Clamping force can be infinitely adjustable within maximum recommended torque limits and no further load is applied during installation of the lock collar. The fastener is available in two types. The Asp® has full shank and the 2Asp® has a pilot type shank. [Figures 7-76 and 7-77]

Hi-Lok® and Huck-Spin® Lockbolt Fasteners

Most composite primary structures for the aircraft industry are fastened with Hi-Loks® (Hi-Shear Corp.) or Huck-Spin® lockbolts for permanent installations. The Hi-Lok® is a threaded fastener that incorporates a hex key in the threaded end to react to the torque applied to the collar during installation. The collar includes a frangible portion that separates at a predetermined torque value. [Figure 7-78]

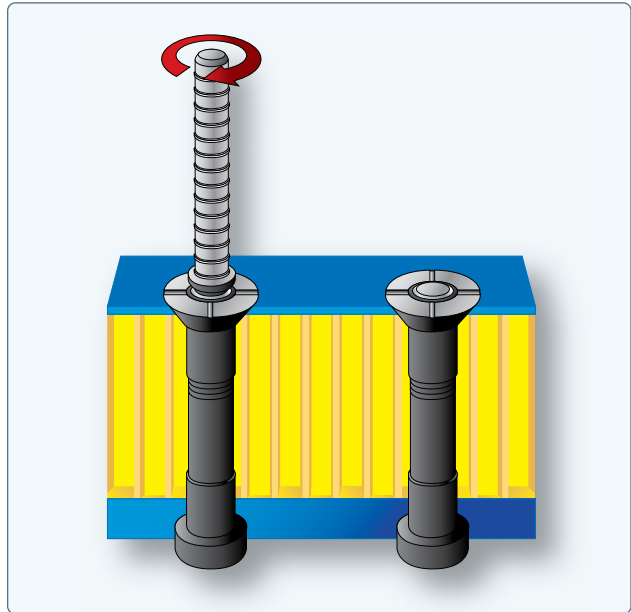

Figure 7-76. ASP fastener system.

The Lockbolt incorporates a collar that is swaged into annular grooves. It comes in two types: pull and stump. The pull-type is the most common, where a frangible pintail is used to react the axial load during the swaging of the collar. When the swaging load reaches a predetermined limit, the pintail breaks away at the breakneck groove. The installation of the Hi-Lok® and the pull-type Huck-Spin® lockbolt can be performed by one technician from one side of the structure. The stump-type Lockbolt, on the other hand, requires support on the head side of the fastener to react the swage operation. This method is usually reserved for automated assembly of detail structure in which access is not a problem.

The specific differences in these fasteners for composite structure in contrast to metal structure are small. For the Hi-Lok®, material compatibility is the only issue; aluminum collars are not recommended. Standard collars of A286, 303 stainless steel, and titanium alloy are normally used. The Huck-Spin® lockbolt requires a hat-shaped collar that incorporates a flange to spread the high bearing loads during installation. The Lockbolt pin designed for use in composite structure has six annular grooves as opposed to five for metal structure. [Figures 7-79 and 7-80]

Eddie-Bolt® Fasteners

Eddie-Bolt® fasteners (Alcoa) are similar in design to Hi-Loks® and are a natural choice for carbon fiber composite structures. The Eddie-Bolt® pin is designed with flutes in the threaded portion, which allow a positive lock to be made during installation using a specially designed mating nut or collar. The mating nut has three lobes that serve as driving ribs. During installation, at a predetermined preload, the lobes

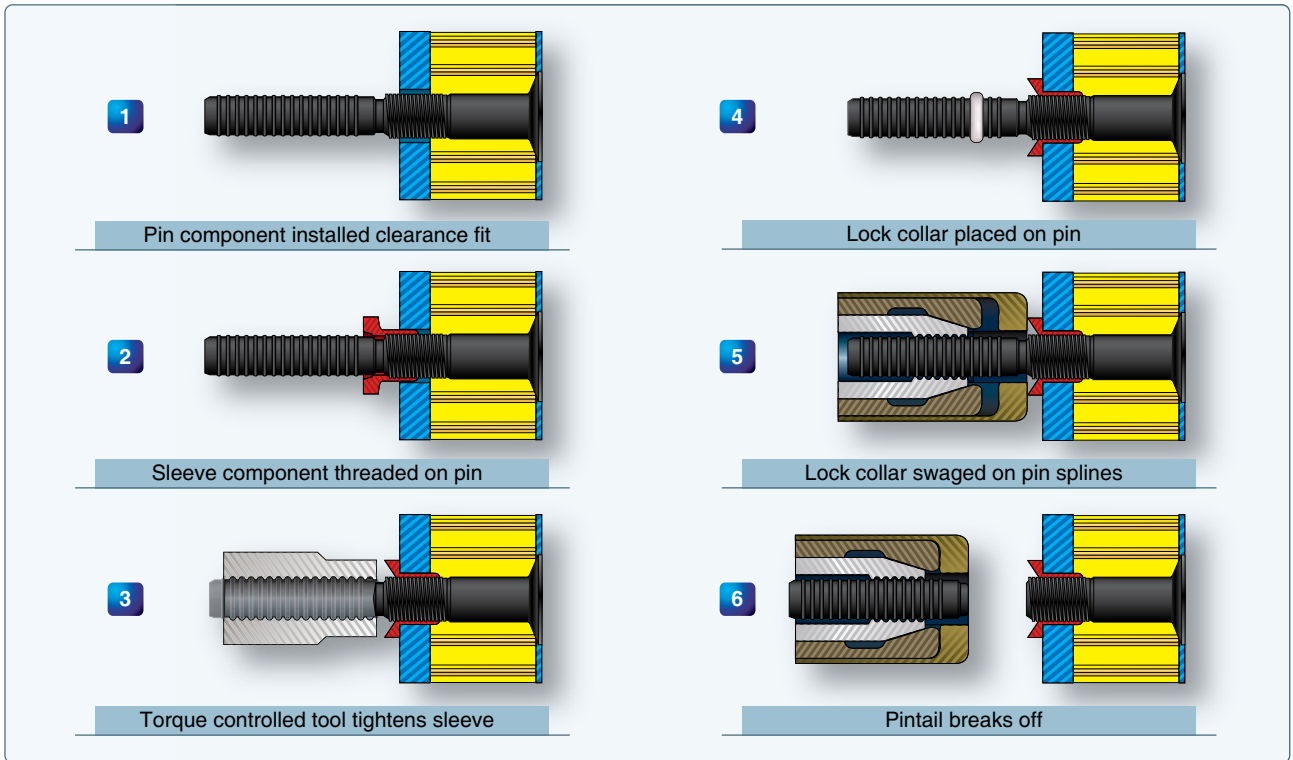

Figure 7-77. ASP fastener system installation sequence.

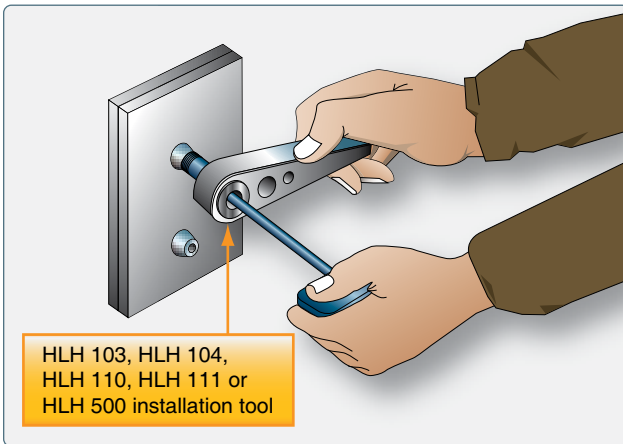

Figure 7-78. Hi-Lok® installation.

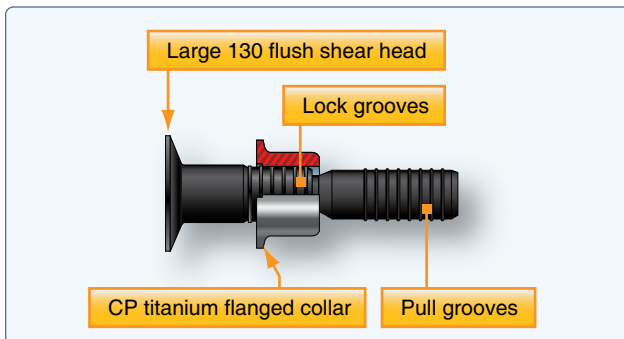

Figure 7-79. Huck-Spin® lockbolt.

compress the nut material into the flutes of the pin and form the locking feature. The advantage for composite structure is that titanium alloy nuts can be used for compatibility and weight saving without the fear of galling. The nuts spin on freely, and the locking feature is established at the end of the installation cycle. [Figure 7-81]

Cherry's E-Z Buck® (CSR90433) Hollow Rivet

The Cherry Hollow End E-Z Buck® rivet is made from titanium/columbium alloy and has a shear strength of 40 KSI. The E-Z Buck® rivet is designed to be used in a double flush application for fuel tanks. The main advantage of this type of rivet is that it takes less than half the force of a solid rivet of the same material. The rivets are installed with automated riveting equipment or a rivet squeezer. Special optional dies ensure that the squeezer is always centered during installation, avoiding damage to the structure. [Figure 7-82]

Blind Fasteners

Composite structures do not require as many fasteners as metal aircraft because stiffeners and doublers are co-cured with the skins, eliminating many fasteners. The size of panels on aircraft has increased in composite structures, which causes backside inaccessibility. Therefore, blind fasteners or screws and nutplates must be used in these areas. Many manufacturers make blind fasteners for composite structures; a few are discussed below.

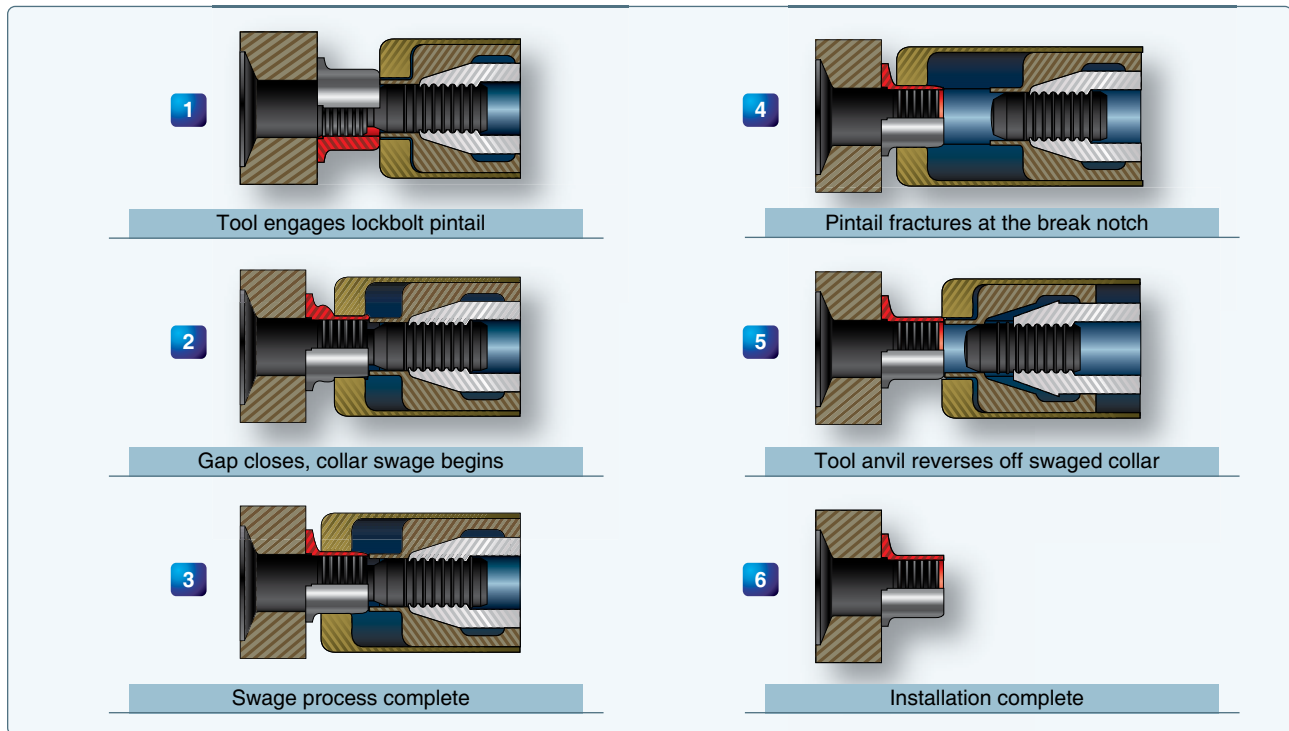

Figure 7-80. Huck-Spin® installation sequence.



Figure 7-81. Eddie Bolts®.

Blind Bolts

The Cherry Maxibolt® is available in titanium for compatibility with composite structures. The shear strength of the Maxibolt® is 95 KSI. It can be installed from one side with a G-83 or equivalent pneumatic-hydraulic installation tool, and is available in 100° flush head, 130° flush head and protruding head styles. [Figure 7-83]

The Alcoa UAB™ blind bolt system is designed for composite structures and is available in titanium and stainless steel. The UAB™ blind bolt system is available in 100° flush head, 130° flush head, and protruding head styles.

The Accu-Lok™ Blind Fastening System is designed specifically for use in composite structures in which access is limited to one side of the structure. It combines high joint preload with a large diameter footprint on the blind side. The large footprint enables distribution of the joint preload over a larger area, virtually eliminating the possibility of delaminating the composite structure. The shear strength of the Accu-Lok™ is 95 KSI, and it is available in 100° flush head, 130° flush head, and protruding head styles. A similar fastener designed by Monogram is called the Radial-Lok®. [Figure 7-84]

Fiberlite

The fiberlite fastening system uses composite materials for a wide range of aerospace hardware. The strength of fiberlite fasteners is equivalent to aluminum at two-thirds the weight. The composite fastener provides good material compatibility with carbon fiber and fiberglass.

Screws and Nutplates in Composite Structures

The use of screws and nutplates in place of Hi-Loks® or blind fasteners is recommended if a panel must be removed periodically for maintenance. Nutplates used in composite structures usually require three holes: two for attachment of the nutplate and one for the removable screw, although rivetless nut plates and adhesive bonded nutplates are available that do not require drilling and countersinking two extra holes.

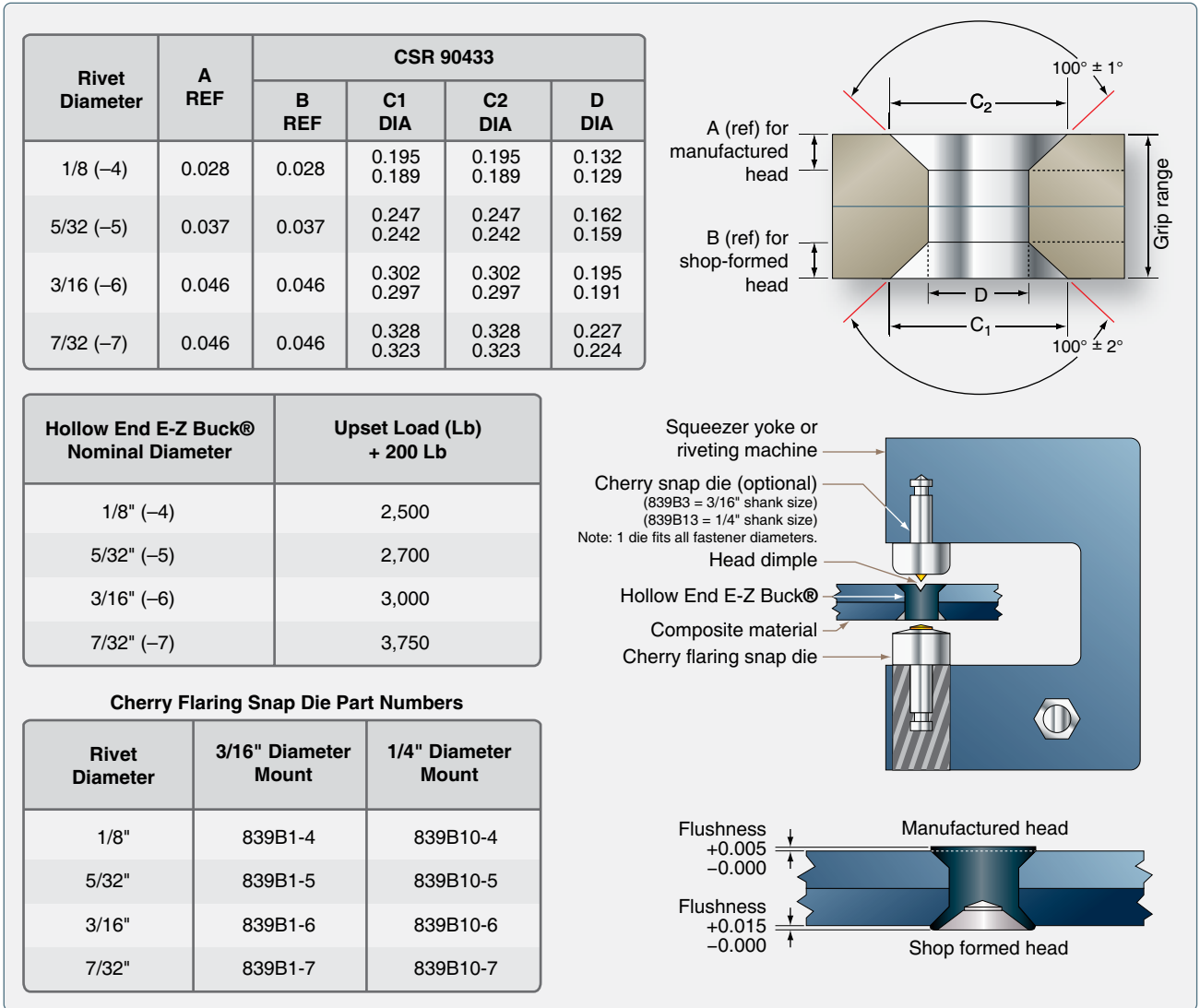

Figure 7-82. Cherry's E-Z buck hollow rivet.

Machining Processes and Equipment

Drilling

Hole drilling in composite materials is different from drilling holes in metal aircraft structures. Different types of drill bits, higher speeds, and lower feeds are required to drill precision holes. Structures made from carbon fiber and epoxy resin are very hard and abrasive, requiring special flat flute drills or similar four-flute drills. Aramid fiber (Kevlar®)/epoxy composites are not as hard as carbon but are difficult to drill unless special cutters are used because the fibers tend to fray or shred unless they are cut clean while embedded in the epoxy. Special drill bits with clothes pin points and fish-tail points have been developed that slice the fibers prior to pulling them out of the drilled hole. If the Kevlar®/epoxy part is sandwiched between two metal parts, standard twist drills can be used.

Equipment

Air-driven tools are used for drilling holes in composite materials. Drill motors with free speed of up to 20,000 rpm are used. A general rule for drilling composites is to use high speed and a low feed rate (pressure). Drilling equipment with a power feed control produces better hole quality than drill motors without power feed control. Drill guides are recommended, especially for thicker laminates.

Do not use standard twist drill bits for drilling composite structures. Standard high-speed steel is unacceptable, because it dulls immediately, generates excessive heat, and causes ply delamination, fiber tear-out, and unacceptable hole quality.

Drill bits used for carbon fiber and fiberglass are made from diamond-coated material or solid carbide because the fibers

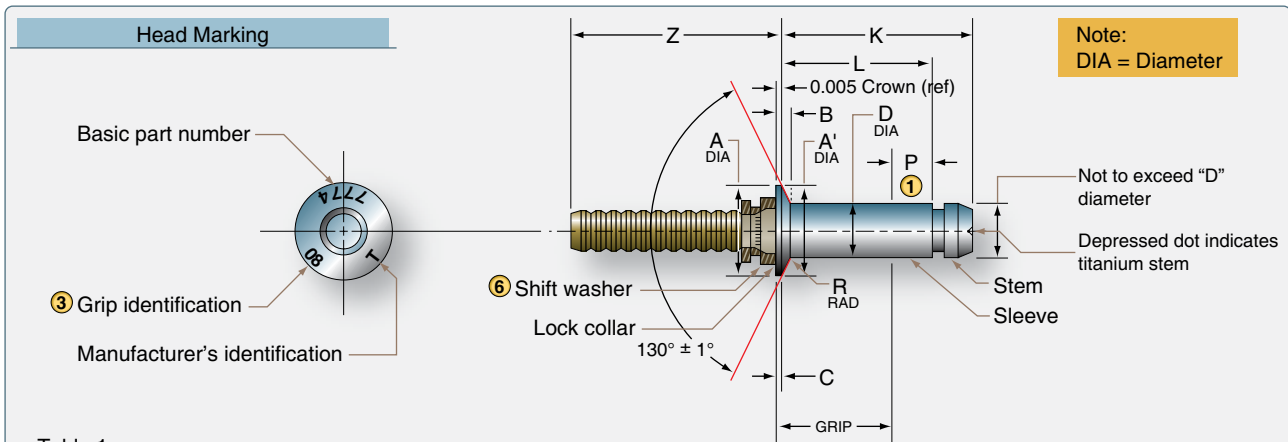

Table 1

Dia. Dash No.	D ± 0.001 ⑥	A Max	A' Min	B Max	P Max	R Max	Z Min	Hole Limits	Installed Strength (Lb) ④	
									Single Shear Minimum ⑤	Tensile Minimum
-05	0.163	0.333	0.296	0.039	0.215	0.025	0.844	0.164/0.167	1980	900
-06	0.198	0.386	0.342	0.043	0.250	0.025	0.875	0.199/0.202	2925	1400
-06	0.259	0.507	0.463	0.057	0.305	0.030	1.000	0.260/0.263	5005	2100

Table 2

Grip Dash No.	Grip Limits				-05 Diameter		Grip Limits				-06 Diameter		-08 Diameter	
	Overlap Min	1/16 Range ④		Overlap Max	L Ref	K Max	Overlap Min	1/16 Range ④		Overlap Max	L Ref	K Max	L Ref	K Max
		Min	Max					Min	Max					
-02	—	0.094	0.157	0.173	0.336	0.476	—	0.120	0.157	0.173	0.355	0.521	—	—
-03	0.146	0.154	0.220	0.236	0.398	0.536	⑨	0.156	0.220	0.236	0.417	0.584	0.479	0.645
-04	0.209	0.219	0.282	0.298	0.460	0.602	0.203	0.219	0.282	0.298	0.480	0.647	0.541	0.708
-05	0.271	0.281	0.345	0.361	0.523	0.664	0.265	0.281	0.345	0.361	0.542	0.709	0.604	0.770
-06	0.334	0.344	0.407	0.423	0.585	0.727	0.328	0.344	0.407	0.423	0.605	0.772	0.666	0.833
-07	0.396	0.406	0.470	0.486	0.648	0.789	0.390	0.406	0.470	0.486	0.667	0.834	0.729	0.895
-08	0.459	0.469	0.532	0.548	0.710	0.852	0.453	0.469	0.532	0.548	0.730	0.897	0.791	0.958
-09	0.521	0.531	0.595	0.611	0.773	0.914	0.515	0.531	0.595	0.611	0.792	0.959	0.854	1.020
-10	0.584	0.594	0.657	0.673	0.835	0.977	0.578	0.594	0.657	0.673	0.855	1.022	0.916	1.083
-11	0.646	0.656	0.720	0.736	0.898	1.039	0.640	0.656	0.720	0.736	0.917	1.084	0.979	1.145
-12	0.709	0.719	0.782	0.798	0.960	1.102	0.703	0.719	0.782	0.798	0.980	1.147	1.041	1.208

Figure 7-83. Cherry's titanium Maxibolt.

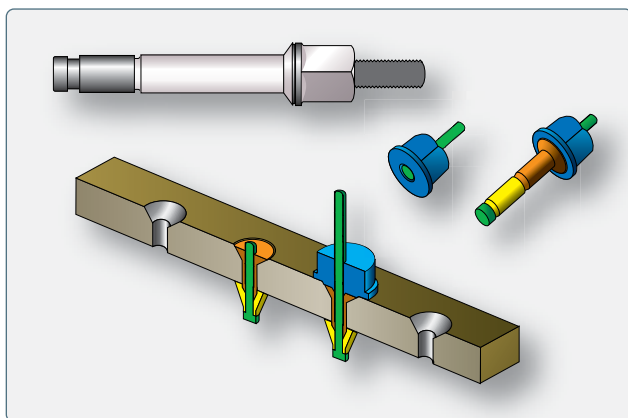

Figure 7-84. Accu-Lok™ installation.

are so hard that standard high-speed steel (HSS) drill bits do not last long. Typically, twist drills are used, but brad point drills are also available. The Kevlar® fibers are not as hard as carbon, and standard HSS drill bits can be used. The hole quality can be poor if standard drill bits are used and the preferred drill style is the sickle-shaped Klenk drill. This drill first pulls on the fibers and then shears them, which results in a better quality hole. Larger holes can be cut with diamond-coated hole saws or fly cutters, but only use fly cutters in a drill press, and not in a drill motor. [Figures 7-85, 7-86, and 7-87]

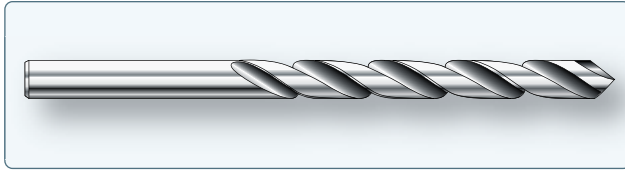

Figure 7-85. Klenk-type drill for drilling Kevlar®.



Figure 7-86. Drilling and cutting tools for composite materials.



Figure 7-87. Autofeed drill.

Processes and Precautions

Composite materials are drilled with drill motors operating between 2,000 and 20,000 rpm and a low feed rate. Drill motors with a hydraulic dash pod or other type of feed control are preferred because they restrict the surging of the drill as it exits the composite materials. This reduces breakout damage and delaminations. Parts made from tape products are especially susceptible to breakout damage; parts made from fabric material have experienced less damage. The composite structure needs to be backed with a metal plate or sheet to avoid breakout. Holes in composite structures are often predrilled with a small pilot hole, enlarged with a diamond-coated or carbide drill bit and reamed with a carbide reamer to final hole size.

Back counterboring is a condition that can occur when carbon/epoxy parts mate metal substructure parts. The back edge of the hole in the carbon/epoxy part can be eroded or radiused by metal chips being pulled through the composite. The condition is more prevalent when there are gaps between the parts or when the metal debris is stringy rather than small chips. Back counterboring can be minimized or eliminated by changing feeds and speeds, cutter geometry, better part clamp-up adding a final ream pass, using a peck drill, or combination of these.

When drilling combinations of composite parts with metal parts, the metal parts may govern the drilling speed. For example, even though titanium is compatible with carbon/epoxy material from a corrosion perspective, lower drilling speeds are required in order to ensure no metallurgical damage occurs to the titanium. Titanium is drilled with low speed and high feed. Drill bits suitable for titanium might not be suitable for carbon or fiberglass. Drill bits that are used for drilling titanium are often made from cobalt-vanadium; drill bits used for carbon fiber are made from carbide or are diamond coated to increase drill life and to produce an accurate hole. Small-diameter high-speed steel (HSS) drill bits, such as No. 40 drill, which are used to manually drill pilot holes, are typically used because carbide drills are relatively brittle and are easily broken. The relatively low cost of these small HSS drill bits offsets the limited life expectancy. High-speed steel drill bits may last for only one hole.

The most common problem with carbide cutters used in hand-drill operations is handling damage (chipped edges) to the cutters. A sharp drill with a slow constant feed can produce a 0.1 mm (0.004-inch) tolerance hole through carbon/epoxy plus thin aluminum, especially if a drill guide is used. With hard tooling, tighter tolerances can be maintained. When the structure under the carbon/epoxy is titanium, drills can pull titanium chips through the carbon/epoxy and enlarge the hole. In this case, a final ream operation may be required to hold tight hole tolerances. Carbide reamers are needed for holes through carbon/epoxy composite structure. In addition, the exit end of the hole needs good support to prevent splintering and delaminations when the reamer removes more than about 0.13 mm (0.005-inch) on the diameter. The support can be the substructure or a board held firmly against the back surface. Typical reaming speeds are about one-half of the drilling speed.

Cutting fluids are not normally used or recommended for drilling thin (less than 6.3 mm, or 0.25-inch thick) carbon/epoxy structure. It is good practice to use a vacuum while drilling in composite materials to avoid that carbon dust freely floats around the work area.

Countersinking

Countersinking a composite structure is required when flush head fasteners are to be installed in the assembly. For metallic structures, a 100° included angle shear or tension head fastener has been the typical approach. In composite structures, two types of fastener are commonly used: a 100° included angle tension head fastener or a 130° included angle head fastener. The advantage of the 130° head is that the fastener head can have about the same diameter as a tension head 100° fastener with the head depth of a shear-type head 100° fastener. For seating flush fasteners in composite parts, it is recommended that the countersink cutters be designed to produce a controlled radius between the hole and the countersink to accommodate the head-to-shank fillet radius on the fasteners. In addition, a chamfer operation or a washer may be required to provide proper clearance for protruding head fastener head-to-shank radii. Whichever head style is used, a matching countersink/chamfer must be prepared in the composite structure.

Carbide cutters are used for producing a countersink in carbon/epoxy structure. These countersink cutters usually have straight flutes similar to those used on metals. For Kevlar® fiber/epoxy composites, S-shaped positive rake cutting flutes are used. If straight-fluted countersink cutters are used, a special thick tape can be applied to the surface to allow for a clean cutting of the Kevlar® fibers, but this is not as effective as the S-shaped fluted cutters. Use of a piloted countersink cutter is recommended because it ensures better concentricity between the hole and the countersink and decreases the possibility of gaps under the fasteners due to misalignment or delaminations of the part.

Use a microstop countersink gauge to produce consistent countersink wells. Do not countersink through more than 70 percent of the skin depth because a deeper countersink well reduces material strength. When a piloted countersink cutter is used, the pilot must be periodically checked for wear, as wear can cause reduction of concentricity between the hole and countersink. This is especially true for countersink cutters with only one cutting edge. For piloted countersink cutters, position the pilot in the hole and bring the cutter to full rpm before beginning to feed the cutter into the hole and preparing the countersink. If the cutter is in contact with the composite before triggering the drill motor, you may get splintering.

Cutting Processes and Precautions

Cutters that work well for metals would either have a short life or produce a poorly cut edge if used for composite materials. The cutters that are used for composites vary with

the composite material that is being cut. The general rule for cutting composites is high speed and slow feed.

- Carbon fiber reinforced plastics: Carbon fiber is very hard and quickly wears out high speed steel cutters. For most trimming and cutting tasks, diamond grit cutters are best. Aluminum-oxide or silicon-carbide sandpaper or cloth is used for sanding. Silicon-carbide lasts longer than aluminum-oxide. Router bits can also be made from solid carbide or diamond coated.
- Glass fiber reinforced plastics: Glass fibers, like carbon, are very hard and quickly wear out high-speed steel cutters. Fiberglass is drilled with the same type and material drill bits as carbon fiber.
- Aramid (Kevlar®) fiber-reinforced plastics: Aramid fiber is not as hard as carbon and glass fiber, and cutters made from high-speed steel can be used. To prevent loose fibers at the edge of aramid composites, hold the part and then cut with a shearing action. Aramid composites need to be supported with a plastic backup plate. The aramid and backup plate are cut through at the same time. Aramid fibers are best cut by being held in tension and then sheared. There are specially shaped cutters that pull on the fibers and then shear them. When using scissors to cut aramid fabric or prepreg, they must have a shearing edge on one blade and a serrated or grooved surface on the other. These serrations hold the material from slipping. Sharp blades should always be used as they minimize fiber damage. Always clean the scissor serrations immediately after use so the uncured resin does not ruin the scissors.

Always use safety glasses and other protective equipment when using tools and equipment.

Cutting Equipment

The bandsaw is the equipment that is most often used in a repair shop for cutting composite materials. A toothless carbide or diamond-coated saw blade is recommended. A typical saw blade with teeth does not last long if carbon fiber or fiberglass is cut. [Figure 7-88] Air-driven hand tools, such as routers, saber saws, die grinders, and cut-off wheels can be used to trim composite parts. Carbide or diamond-coated cutting tools produce a better finish and they last much longer. Specialized shops have ultrasonic, waterjet, and laser cutters. These types of equipment are numerical controlled (NC) and produce superior edge and hole quality. A waterjet cutter cannot be used for honeycomb structure because it introduces water in the part. Do not cut anything else on equipment that is used for composites because other materials can contaminate the composite material.



Figure 7-88. Bandsaw.

Prepreg materials can be cut with a CNC Gerber table. The use of this equipment speeds up the cutting process and optimizes the use of the material. Design software is available that calculates how to cut plies for complex shapes. [Figures 7-89]



Figure 7-89. Gerber cutting table.

Repair Safety

Advanced composite materials including prepreg, resin systems, cleaning solvents, and adhesives could be hazardous, and it is important that you use personal protection equipment. It is important to read and understand the Material Safety Data Sheets (MSDS) and handle all chemicals, resins, and fibers correctly. The MSDS lists the hazardous chemicals in the material system, and it outlines the hazards. The material could be a respiratory irritant or carcinogenic, or another kind of dangerous substance.

Eye Protection

Always protect eyes from chemicals and flying objects. Wear safety glasses at all times and, when mixing or pouring acids,

wear a face shield. Never wear corrective contact lenses in a shop, even with safety glasses. Some of the chemical solvents can melt the lenses and damage eyes. Dust can also get under the lenses, causing damage.

Respiratory Protection

Do not breathe carbon fiber dust and always ensure that there is a good flow of air where the work is performed. Always use equipment to assist in breathing when working in a confined space. Use a vacuum near the source of the dust to remove the dust from the air. When sanding or applying paint, you need a dust mask or a respirator. A properly fitted dust mask provides the protection needed. For application of paints, a sealed respirator with the correct filters or a fresh air supply respirator is required.

Downdraft Tables

A downdraft table is an efficient and economical device for protecting workers from harmful dust caused by sanding and grinding operations. The tables are also useful housekeeping tools because the majority of particulate material generated by machining operations is immediately collected for disposal. Downdraft tables should be sized and maintained to have an average face velocity between 100 and 150 cubic feet per minute. The downdraft table draws contaminants like dust and fibers away from the operator's material. Downdraft tables should be monitored and filters changed on a regular basis to provide maximum protection and particulate collection.

Skin Protection

During composite repair work, protect your skin from hazardous materials. Chemicals could remain on hands that burn sensitive skin. Always wear gloves and clothing that offer protection against toxic materials. Use only approved gloves that protect skin and do not contaminate the composite material. Always wash hands prior to using the toilet or eating. Damaged composite components should be handled with care. Single fibers can easily penetrate the skin, splinter off, and become lodged in the skin.

Fire Protection

Most solvents are flammable. Close all solvent containers and store in a fireproof cabinet when not in use. Make sure that solvents are kept away from areas where static electricity can occur. Static electricity can occur during sanding operations or when bagging material is unrolled. It is preferable to use air-driven tools. If electric tools are used, ensure that they are the enclosed type. Do not mix too much resin. The resin could overheat and start smoking caused by the exothermic process. Ensure that a fire extinguisher is always nearby.

Transparent Plastics

Plastics cover a broad field of organic synthetic resin and may be divided into two main classifications: thermoplastics and thermosetting plastics.

- a. Thermoplastics—may be softened by heat and can be dissolved in various organic solvents. Acrylic plastic is commonly used as a transparent thermoplastic material for windows, canopies, etc. Acrylic plastics are known by the trade names of Lucite® or Plexiglas® and by the British as Perspex®, and meet the military specifications of MIL-P-5425 for regular acrylic and MIL-P-8184 for craze-resistant acrylic.
- b. Thermosetting plastics—do not soften appreciably under heat but may char and blister at temperatures of 240–260 °C (400–500 °F). Most of the molded products of synthetic resin composition, such as phenolic, urea-formaldehyde, and melamine formaldehyde resins, belong to the thermosetting group. Once the plastic becomes hard, additional heat does not change it back into a liquid as it would with a thermoplastic.

Optical Considerations

Scratches and other types of damage that obstruct the vision of the pilots are not acceptable. Some types of damage might be acceptable at the edges of the windshield.

Identification

Storage and Handling

Because transparent thermoplastic sheets soften and deform when they are heated, they must be stored where the temperature never becomes excessive. Store them in a cool, dry location away from heating coils, radiators, or steam pipes, and away from such fumes as are found in paint spray booths or paint storage areas.

Keep paper-masked transparent sheets out of the direct rays of the sun, because sunlight accelerates deterioration of the adhesive, causing it to bond to the plastic, and making it difficult to remove.

Store plastic sheets with the masking paper in place, in bins that are tilted at a 10° angle from the vertical to prevent buckling. If the sheets are stored horizontally, take care to avoid getting dirt and chips between them. Stacks of sheets must never be over 18 inches high, with the smallest sheets stacked on top of the larger ones so there is no unsupported overhang. Leave the masking paper on the sheets as long as possible, and take care not to scratch or gouge the sheets by sliding them against each other or across rough or dirty tables.

Store formed sections with ample support so they do not lose their shape. Vertical nesting should be avoided. Protect formed parts from temperatures higher than 120 °F (49 °C), and leave their protective coating in place until they are installed on the aircraft.

Forming Procedures and Techniques

Transparent acrylic plastics get soft and pliable when they are heated to their forming temperatures and can be formed to almost any shape. When they cool, they retain the shape to which they were formed. Acrylic plastic may be cold-bent into a single curvature if the material is thin and the bending radius is at least 180 times the thickness of the sheet. Cold bending beyond these limits impose so much stress on the surface of the plastic that tiny fissures or cracks, called crazing, form.

Heating

Wear cotton gloves when handling the plastic to eliminate finger marks on the soft surface. Before heating any transparent plastic material, remove all of the masking paper and adhesive from the sheet. If the sheet is dusty or dirty, wash it with clean water and rinse it well. Dry the sheet thoroughly by blotting it with soft absorbent paper towels.

For the best results when hot forming acrylics, adhere to the temperatures recommended by the manufacturer. Use a forced-air oven that can operate over a temperature range of 120–374 °F (49–190 °C). If the part gets too hot during the forming process, bubbles may form on the surface and impair the optical qualities of the sheet.

For uniform heating, it is best to hang the sheets vertically by grasping them by their edges with spring clips and suspending the clips in a rack. [Figure 7-90] If the piece is too small to hold with clips, or if there is not enough trim area, lay the sheets on shelves or racks covered with soft felt or flannel. Be sure there is enough open space to allow the air to circulate around the sheet and heat it evenly.

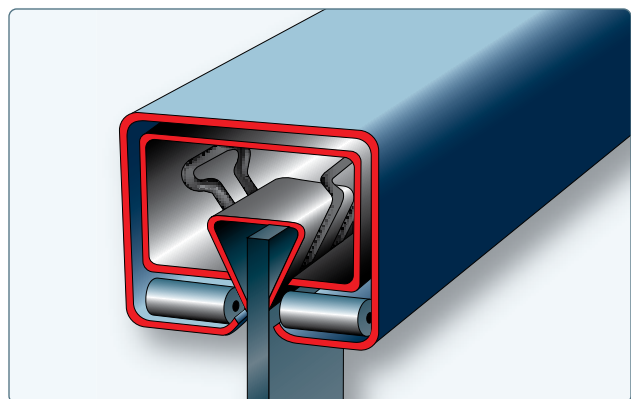

Figure 7-90. Hanging an acrylic sheet.

Small forming jobs, such as landing light covers, may be heated in a kitchen baking oven. Infrared heat lamps may be used if they are arranged on 7 to 8-inch centers and enough of them are used in a bank to heat the sheet evenly. Place the lamps about 18-inches from the material.

Never use hot water or steam directly on the plastic to heat it because this likely causes the acrylic to become milky or cloudy.

Forms

Heated acrylic plastic molds with almost no pressure, so the forms used can be of very simple construction. Forms made of pressed wood, plywood, or plaster are adequate to form simple curves, but reinforced plastic or plaster may be needed to shape complex or compound curves. Since hot plastic conforms to any waviness or unevenness, the form used must be completely smooth. To ensure this, sand the form and cover it with soft cloth, such as outing flannel or billiard felt. The mold should be large enough to extend beyond the trim line of the part, and provisions should be made for holding the hot plastic snug against the mold as it cools.

A mold can be made for a complex part by using the damaged part itself. If the part is broken, tape the pieces together, wax or grease the inside so the plaster does not stick to it, and support the entire part in sand. Fill the part with plaster and allow it to harden, and then remove it from the mold. Smooth out any roughness and cover it with soft cloth. It is now ready to use to form the new part.

Forming Methods

Simple Curve Forming

Heat the plastic material to the recommended temperature, remove it from the heat source, and carefully drape it over the prepared form. Carefully press the hot plastic to the form and either hold or clamp the sheet in place until it cools. This process may take from 10–30 minutes. Do not force cool it.

Compound Curve Forming

Compound curve forming is normally used for canopies or complex wingtip light covers, and it requires a great deal of specialized equipment. There are four commonly used methods, each having its advantages and disadvantages.

Stretch Forming

Preheated acrylic sheets are stretched mechanically over the form in much the same way as is done with the simple curved piece. Take special care to preserve uniform thickness of the material, since some parts must stretch more than others.

Male and Female Die Forming

Male and female die forming requires expensive matching male and female dies. The heated plastic sheet is placed between the dies that are then mated. When the plastic cools, the dies are opened.

Vacuum Forming Without Forms

Many aircraft canopies are formed by this method. In this process, a panel, which has cut into it the outline of the desired shape, is attached to the top of a vacuum box. The heated and softened sheet of plastic is then clamped on top of the panel. When the air in the box is evacuated, the outside air pressure forces the hot plastic through the opening and forms the concave canopy. It is the surface tension of the plastic that shapes the canopy.

Vacuum Forming With a Female Form

If the shape needed is other than that which would be formed by surface tension, a female mold, or form must be used. It is placed below the plastic sheet and the vacuum pump is connected. When air from the form is evacuated, the outside air pressure forces the hot plastic sheet into the mold and fills it.

Sawing and Drilling

Sawing

Several types of saws can be used with transparent plastics; however, circular saws are the best for straight cuts. The blades should be hollow ground or have some set to prevent binding. After the teeth are set, they should be side dressed to produce a smooth edge on the cut. Band saws are recommended for cutting flat acrylic sheets when the cuts must be curved or where the sheet is cut to a rough dimension to be trimmed later. Close control of size and shape may be obtained by band sawing a piece to within $\frac{1}{16}$ -inch of the desired size, as marked by a scribed line on the plastic, and then sanding it to the correct size with a drum or belt sander.

Drilling

Unlike soft metal, acrylic plastic is a very poor conductor of heat. Make provisions for removing the heat when drilling. Deep holes need cooling, and water-soluble cutting oil is a satisfactory coolant since it has no tendency to attack the plastic.

The drill used on acrylics must be carefully ground and free from nicks and burrs that would affect the surface finish. [Figure 7-91] Grind the drill with a greater included angle than would be used for soft metal. The rake angle should be zero in order to scrape, and not cut.

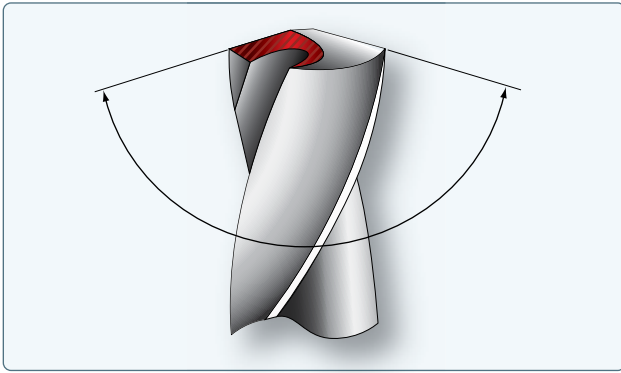

Figure 7-91. A twist drill with an included angle of 150° is used to drill acrylic plastics.

The patented Unibit® is good for drilling small holes in aircraft windshields and windows. [Figure 7-92] It can cut holes from 1/8 to 1/2-inch in 1/32-inch increments and produces good smooth holes with no stress cracks around their edges.

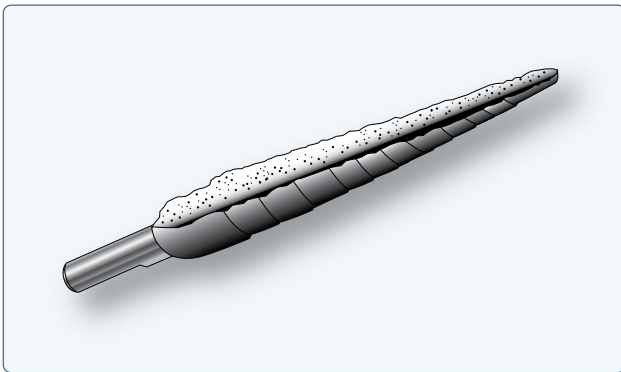

Figure 7-92. Unibit® drill for drilling acrylic plastics.

Cementing

Polymerizable cements are those in which a catalyst is added to an already thick monomer-polymer syrup to promote rapid hardening. Cement PS-30® and Weld-On 40® are polymerizable cements of this type. They are suitable for cementing all types of plexiglas acrylic cast sheet and parts molded from plexiglas molding pellets. At room temperature, the cements harden (polymerize) in the container in about 45 minutes after mixing the components. They harden more rapidly at higher temperatures. The cement joints are usually hard enough for handling within 4 hours after assembly. The joints may be machined within 4 hours after assembly, but it is better to wait 24 hours.

Application of Cement

PS-30® and Weld-On 40® joints retain excellent appearance and color stability after outdoor exposure. These cements produce clear, transparent joints and should be used when the color and appearance of the joints are important.

PS-30® and Weld-On 40® should be used at temperatures no lower than 65 °F. If cementing is done in a room cooler than 65 °F, it requires a longer time to harden and the joint strength is reduced.

The cement should be prepared with the correct proportions of components as given in the manufacturer's instructions and thoroughly mixed, making sure neither the mixing container nor mixing paddle adds color or effects the hardening of the cement. Clean glass or polyethylene mixing containers are preferred. Because of their short pot life (approximately 45 minutes), Cement PS-30® and Weld-On 40® must be used quickly once the components are mixed. Time consumed in preparation shortens the effective working time, making it necessary to have everything ready to be cemented before the cements are mixed. For better handling, pour cement within 20 minutes of mixing. For maximum joint strength, the final cement joint should be free of bubbles. It is usually sufficient to allow the mixed cement to stand for 10 minutes before cementing to allow bubbles to rise to the surface. The gap joint technique can only be used with colorless plexiglas acrylic or in cases where joints are hidden. If inconspicuous joints in colored plexiglas acrylic are needed, the parts must be fitted closely, using closed V groove, butt, or arc joints.

Cement forms, or dams, may be made with masking tape as long as the adhesive surface does not contact the cement. This is easily done with a strip of cellophane tape placed over the masking tape adhesive. The tape must be chosen carefully. The adhesive on ordinary cellophane tape prevents the cure of PS-30® and Weld-On 40®. Before actual fabrication of parts, sample joints should be tried to ensure that the tape system used does not harm the cement. Since it is important for all of the cement to remain in the gap, only contact pressure should be used.

Bubbles tend to float to the top of the cement bead in a gap joint after the cement is poured. These cause no problem if the bead is machined off. A small wire (not copper) or similar object may be used to lift some bubbles out of the joint; however, the cement joint should be disturbed as little as possible.

Polymerizable cements shrink as the cement hardens. Therefore, the freshly poured cement bead should be left above the surfaces being cemented to compensate for the shrinkage. If it is necessary for appearances, the bead may be machined off after the cement has set.

Repairs

Whenever possible, replace, rather than repair, extensively damaged transparent plastic. A carefully patched part is not

the equal of a new section, either optically or structurally. At the first sign of crack development, drill a small hole with a # 30 or a 1/8-inch drill at the extreme ends of the cracks. [Figure 7-93] This serves to localize the cracks and to prevent further splitting by distributing the strain over a large area. If the cracks are small, stopping them with drilled holes usually suffices until replacement or more permanent repairs can be made.

Cleaning

Plastics have many advantages over glass for aircraft use, but they lack the surface hardness of glass and care must be exercised while servicing the aircraft to avoid scratching or otherwise damaging the surface. Clean the plastic by washing it with plenty of water and mild soap, using a clean, soft, grit-free cloth, sponge, or bare hands. Do not use gasoline, alcohol, benzene, acetone, carbon tetrachloride, fire extinguisher or deicing fluids, lacquer thinners, or window cleaning sprays. These soften the plastic and cause crazing.

Plastics should not be rubbed with a dry cloth since it is likely to cause scratches and to build up an electrostatic charge that attracts dust particles to the surface. If, after removing dirt and grease, no great amount of scratching is visible, finish the plastic with a good grade of commercial wax. Apply the wax in a thin even coat and bring to a high polish by rubbing lightly with a soft cloth.

Polishing

Do not attempt hand polishing or buffing until the surface is clean. A soft, open-type cotton or flannel buffing wheel is suggested. Minor scratches may be removed by vigorously rubbing the affected area by hand, using a soft clean cloth dampened with a mixture of turpentine and chalk, or by applying automobile cleanser with a damp cloth. Remove the cleaner and polish with a soft, dry cloth. Acrylic and cellulose acetate plastics are thermoplastic. Friction created

by buffing or polishing too long in one spot can generate sufficient heat to soften the surface. This condition produces visual distortion and should be avoided.

Windshield Installation

Use material equivalent to that originally used by the manufacturer of the aircraft for replacement panels. There are many types of transparent plastics on the market. Their properties vary greatly, particularly expansion characteristics, brittleness under low temperatures, resistance to discoloration when exposed to sunlight, surface checking, etc. Information on these properties is in MIL-HDBK-17, Plastics for Flight Vehicles, Part II Transparent Glazing Materials, available from the Government Printing Office (GPO). These properties are considered by aircraft manufacturers in selecting materials to be used in their designs and the use of substitutes having different characteristics may result in subsequent difficulties.

Installation Procedures

When installing a replacement panel, use the same mounting method employed by the manufacturer of the aircraft. While the actual installation varies from one type of aircraft to another, consider the following major principles when installing any replacement panel.

1. Never force a plastic panel out of shape to make it fit a frame. If a replacement panel does not fit easily into the mounting, obtain a new replacement or heat the whole panel and re-form. When possible, cut and fit a new panel at ordinary room temperature.
2. In clamping or bolting plastic panels into their mountings, do not place the plastic under excessive compressive stress. It is easy to develop more than 1,000 psi on the plastic by overtightening a nut and bolt. Tighten each nut to a firm fit, and then back the nut off one full turn (until they are snug and can still be rotated with the fingers).

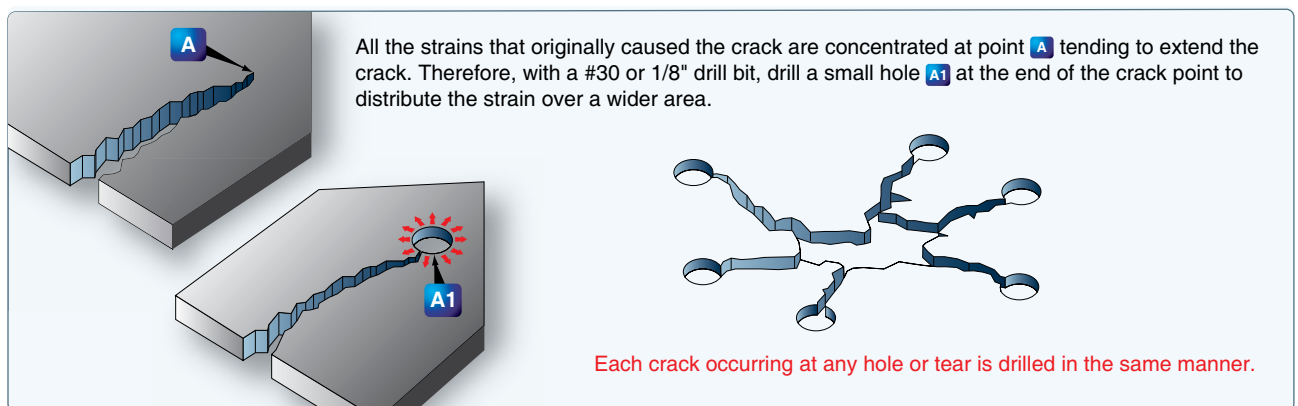

Figure 7-93. Stop drilling of cracks.

3. In bolted installations, use spacers, collars, shoulders, or stop-nuts to prevent tightening the bolt excessively. Whenever such devices are used by the aircraft manufacturer, retain them in the replacement installation. It is important that the original number of bolts, complete with washers, spacers, etc., be used. When rivets are used, provide adequate spacers or other satisfactory means to prevent excessive tightening of the frame to the plastic.
4. Mount plastic panels between rubber, cork, or other gasket material to make the installation waterproof, to reduce vibration, and to help to distribute compressive stresses on the plastic.
5. Plastics expand and contract considerably more than the metal channels in which they are mounted. Mount windshield panels to a sufficient depth in the channel to prevent it from falling out when the panel contracts at low temperatures or deforms under load. When the manufacturer's original design permits, mount panels to a minimum depth of 1 $\frac{1}{8}$ -inches, and with a clearance of $\frac{1}{8}$ -inch between the plastic and bottom of the channel.
6. In installations involving bolts or rivets, make the holes through the plastic oversize by $\frac{1}{8}$ -inch and center so that the plastic does not bind or crack at the edge of the holes. The use of slotted holes is also recommended.